

Graviteam Tactics: Tunisia 1943
Graviteam Tactics: Mius-Front
Graviteam (R)

User guide
Version 2024.03.08

CONTENTS

1 QUICK START	3
1.1 Questions and answers	4
2 OPERATIONAL MODE	6
2.1 List of forces and battle groups	12
2.1.1 Artillery support	15
2.2 Start of a tactical battle	17
2.3 Logistics	20
2.4 Special actions	21
3 TACTICAL MODE	23
3.1 Deployment phase	25
3.2 Initial orders and tactical battle phase	30
3.2.1 System of orders and specifics of their execution	31
3.2.2 Autonomous movement of forces	36
3.2.3 Abandoning knocked out vehicles	38
3.2.4 Enemy detection and concealment	39

3.3 Command level	41
3.3.1 Unit status	42
3.4 Displaying the information and parameters of the selected units	44
3.5 Air and artillery support	58
3.6 Tactical diagrams and armor penetration charts	63
3.6.1 Armor penetration calculation	69
3.6.2 Damage model	70
4 AFTER BATTLE STATISTICS	71
4.1 Using captured weapons and vehicles	74
5 MISCELLANEOUS	75
5.1 Game updating and add-on installation	76
5.2 Armor penetration diagrams in the encyclopedia	77
5.3 Creating modifications	79
APPENDIX	81
Appendix B. Short names of troops on the operational map	81

1 QUICK START

Used terminology:

Unit	single squad or vehicle (tank, APC, gun, etc.)
LMB	left mouse button - used for selection
RMB	right mouse button - used for orders or mode changing
MMB	middle mouse button (mouse wheel)
Operational mode	turn-based 2D map mode, in which platoons are moved
Tactical mode	3D mode in real time, in which battles resulted from the movement of forces in the operational battle are simulated

To start the game click on the QUICK BATTLE menu item, in the appearing list in the TRAINING section, select the type of training mission (it is recommended to start from the "Basic training" mission). Each training mission tells interactively about certain aspects and features of the game.

Table A.1 (in appendix A) shows tactical symbols used in various armies for designation of the forces on a map. To change the display, symbols and color scheme of the forces, click on the OPTIONS item in the main menu, and in the "Game and realism settings" section in the "Markers" group, select the required.

To make a screenshot press **[F12]** key. Resulting image will be placed in the "users\scrshots" folder in the root folder of the game. Images are saved in JPEG format with .jpg extension. Each screenshot name consists from gtmf/twt43 (game name) with a suffix of form: date in YYYY:MM:DD format, time since the start of the day in seconds and the sequence number of the current game session. To create a screenshot without the interface (in tactical battle or statistics mode) press **[Ctrl+F12]** key combination.

1.1 Questions and answers



1	How to select infantry only, without APC?	There are two ways: hold left [Shift] and box select it, or click [LMB] on the squad's secondary icon. Only the 2nd sections of squads will be selected in this case.
2	How to select APC without infantry?	Hold left [Alt] and box select - only the 1st sections of squads (or vehicle) will be selected. The same can be done by holding left [Alt] or [Shift] and clicking on the quick select panel, to select the first or second section, respectively.
3	How to save a battle as a mission?	On the operational map, press [Ctrl+S] in tactical battles mode, set options (name, brief description, image) in the appearing table and press the save button.
4	Why are some order icons colored blue and some modifiers red?	Not all combinations of modifiers are valid for every set of selected units. Modifiers (and orders) which will not be executed or will be executed improperly for the selected set of units are indicated in red (blue) color.
5	How to set a wedge formation for vehicles?	Select only vehicles, set the line formation in 2 or 3 lines.
6	How to make soldiers move crawling?	Set the covert movement modifier and do not select the fast move modifier. The destination point must not be further than 200 meters from the soldier's location.
7	How to call aviation in battle in operations?	In operations, in most cases aviation arrives according to the script, and is not called by spotters.

8	How to make observed fire with crews of machine guns and other heavy weapons?	Turn on the AI control mode for those who will be firing, and select the target through the platoon commander. Make sure that the target is in the zone between the minimum and maximum range of fire!
9	I have no tactical diagrams above vehicles, what to do?	For a tactical diagram to appear, it is necessary for the vehicle to have a target or set it manually by hovering the cursor over the target in the line of fire indication mode.
10	What does the transfer of units under AI control affect?	Automatic laying of wire links, firing at external target designation (designated manually or automatically), automatically leaving trenches.
11	I installed a DLC, but I cannot find it. What to do, where to find it?	Most DLC consist of a pair of operations and a new battlefield. Battlefield can be selected in the quick battle editor. Operations appear in the CAMPAIGN section, in the list of operations in the corresponding section.
12	What are the symbols to the right of the operation picture (square, '?', etc.) mean?	<p>? - have not been updated to the new format yet.</p> <p>Square - the old system of squares is used.</p> <p>Soldier - platoon system is used instead of battle groups.</p> <p>Target - is a small operation.</p> <p>No symbols - battlegroups and hex-grid navigation are used.</p>

2 OPERATIONAL MODE









In this mode, player can move forces, organize their supply and reinforcement, assemble battle groups and start tactical battles. Battlefield in the operational phase consists of two parts: reserve nodes on the perimeter where battles cannot be held (marked by hatching) and active nodes located in the center. Each node can contain 1 platoon or battle group. Each platoon, in turn, consists of several units (Table 2.1), and each battle group (BG) - of several platoons.

Table 2.1 - Unit types

	Command squad and commanders		Scouts and snipers (unmounted and motorized)
	Rifle, SMG and infantry squads		Artillery and air spotters
	Machine-gun squads and heavy weapon squads (ATRs, grenade launchers, flamethrowers)		Assault guns and tank destroyers
	Motor-rifle squads on APC		Tanks
	Heavy infantry weapons (mortars, HMGs)		Towed artillery
	Transport vehicles		Signallers
	Repair and supply crews	*	Defeated unit
	Empty "slot" in excess of organizational table	.	Empty "slot" according to organizational table

Each platoon consists of two parts: main and auxiliary, which is selected via reinforcement strategies (Table 2.2).

Table 2.2 - Platoon reinforcement strategies*

	None, but can be selected	No reinforcement
	Firepower	Platoon is given tanks and SPG or motorized infantry and other reinforcing means with high mobility
	Manpower	Platoon personnel is reinforced with rifle and infantry units or motorized infantry
	Anti-tank	Platoon is given artillery or SPG and special anti-tank means, or even tanks
	Anti-personnel	Platoon is given heavy infantry weapons: grenade launchers, mortars and machine-guns or guns or special means
	Mobility	Platoon will be given transport vehicles: trucks and APC without infantry
	Reinforced support	Artillery and air spotter will be added to platoon
	Patrol	Platoon will be reinforced with scout units (motorized or unmounted) and snipers or motorized infantry
	Supplies	Auxiliary units will be added to platoon: commanders or signallers or supply troops and repair crews.

*types are listed in the descending order of priority

In this mode, each command platoon (company commander, battalion commander, regimental commander) or battle group has the commander's name (or battalion and division number) shown below it. Below platoon/BG (on in table) a circle of various colors can be displayed: **black** - platoon will be disbanded, **green** - platoon has high characteristics, **red** - platoon has low characteristics, **yellow** - platoon is historical (a brief background is provided in the FORCES LIST), **bright blue** - units located in the reserve (several platoons in the same node) and ready for battle.

When selecting a platoon or battle group **[LMB]** green squares indicate the places where it can move to, and orange (or yellow) dots - enemy units which it can attack. Move or attack are done by clicking **[RMB]**.

The game has two movement modes for BG/platoons on the operational map. Modes are switched in the settings (realism/direct control).

1) *Direct control*. In this mode, the player moves BG/platoons every turn himself, selecting the places where they should move by clicking **[RMB]**.

2) *Indirect control*. In this mode, the player gives orders to BG/platoons, rather than moving them himself. An order is given by clicking **[RMB]** anywhere on the battlefield or on the border area, but only in the cells available on this turn, marked with green squares. The orders themselves will be executed prior to the movement of the AI platoons/BG, after pressing the end of turn button. Orders are executed in the order they were given by the player if possible.

Three types of orders are available:

1) Defense - when clicking **[RMB]** on the selected platoon - in this case, the platoon begins digging trenches. Such order is automatically added on completion of any other order if the platoon is located on the battlefield.

2) March - movement with maximum speed, in this case the BG/platoon will try to avoid an engagement with the enemy and will not attack him. But it is vulnerable to enemy attacks in this mode of movement (can be blocked during the deployment phase if attacked by the enemy). The march is automatically selected when clicking **[RMB]** on allied and neutral cells. The march can be changed into attack with another **[RMB]** click on the order marker (except for orders on the border area).

3) Attack - movement in a deployed formation, at a speed of 1 cell per turn. In this mode, the BG/platoon automatically attacks the enemy if he stands in its way. Such an order is automatically selected when clicking **[RMB]** in the enemy area. The probability of blocking at the initial deployment phase is minimal during movement of this type.

To cancel an order click **[RMB]** on its marker again.

Platoon mobility is determined by its type, the presence of transport for personnel transportation and of towed weapons, as well as vehicle condition. If a platoon was entrenching or attacked in the previous turn, its movement is restricted (by ~50% in both cases). If a platoon's personnel is exhausted, movement is also restricted. Broken vehicles of III and IV categories disable movement of a platoon. Also, with the limit night battles setting turned on, platoons and BG will not attack during dark time.

If a platoon was not moving for some turns and was not involved in combat, its mobility is increased for 1 turn. Allied platoons located in the path of movement increase mobility, and enemy platoons - reduce instead. Also, the terrain characteristics along which movement takes place have an important impact, rivers, mountains and swamps reduce mobility, and roads - increase.

The mobility of a battle group is determined by the worst mobility characteristics of its composing platoons.

Each node on the map can have a key point (showed in cell), operational points, which determine victory or defeat, are awarded for capturing and holding such points. Capturing and holding key points usually is the main goal of the game.

If trenches were dug in a node, but this node did not get into battle (as being captured), then these trenches are preserved, and any platoon or BG that came to this node can use these trenches. After a node enters the battle, the entrenchment of the node is removed.

In addition, depending on the operation, operational points can also be awarded for keeping platoons and battle groups in reserve, destruction of enemy forces, taking of territory, or special objectives determined by the operation's goals. For example, retention or destruction of a particular platoon or troops reaching a certain line.

Some operations use a new system for calculating the operational score, which is based on measuring the parameters of the operation, which in turn are determined by the goals of the operation: maintaining combat capability of troops, rate of capturing or holding of key points, defeating enemy troops, etc. Each parameter, depending on the objective, has a range in which it must fall so that the corresponding objective is considered achieved and operational points are counted. Also, each objective has its own "price" within the operation - the number of operational points that can be obtained if the corresponding parameter reaches the maximum value.

The following parameters are measured in the game (different operations may have different combinations):

- 1) Ally and player force strength - a qualitative and quantitative indicator of the state of the allied and player troops.
- 2) Enemy force strength - a qualitative and quantitative state of the enemy troops. At higher difficulty levels, this parameter is shown approximately until the end of the operation.
- 3) Control of key points - the ratio of the number and weight of key points captured by allies or the player to their total number and weight.
- 4) Holding of key points - the rate of holding of key points, in the amount that was at the beginning of the operation. This value is accumulated each turn.
- 5) Capture of key points - the rate of capturing of key points that were not controlled by the player or allies at the beginning of the operation. This value is also accumulated each turn.
- 6) Forces remained in the reserve - the ratio of forces that have not entered the battle to the total number of player forces. Staff and support units that are outside the map border and cannot move are not counted.
- 7) Special tasks of the operation, which are determined by the script of the operation. For example, the need to preserve some units for withdrawing them from battle. These tasks provide operational points in excess of the total amount (available not in every operation).

Some objectives are primary, some are secondary. If at least one of the primary objectives is not fulfilled (if the corresponding parameter goes out of the specified range at the end of the operation), the operation is considered failed and ends in defeat, regardless of the operational score. Secondary objectives can be met or not, this only affects the value of the operational score.

You can see what objectives (parameters) will be set and their "price" before beginning an operation. Current state of the parameters, which objectives have been achieved and which have not, as well as the total number of operational points are displayed at each turn of the operation.

To win the operation, you must achieve all primary objectives of the operation, as well as accumulate a number of points V , not less than the specified one, which is determined by the difficulty level. The value V is defined for the easy level as $\frac{1}{3}$ of the primary objectives, and for the normal level $\frac{1}{2}$ of the primary and $\frac{1}{4}$ of the secondary objectives. For the high difficulty level, $\frac{2}{3}$ and $\frac{1}{3}$ of the

primary and secondary objectives, respectively. And at the maximum difficulty level, it is necessary to achieve $\frac{3}{4}$ of the primary and $\frac{1}{2}$ of the secondary objectives.

If every primary objective is met, but the specified number of operational points V is not achieved, then there will be a draw. If level V is reached or slightly exceeded, then a minor victory in the operation will be counted. If the level is exceeded by 25% of the difference between the maximum number of points and V , then an unconditional victory will be counted, and if it is exceeded by 50%, then a complete victory. Defeat is graded according to the same principle -25% and -50% of level V - defeat and total defeat, respectively. In all other cases, minor defeat.

2.1 List of forces and battle groups

Click **[RMB]** or **[MMB]** (for indirect control) on your platoon or battle group to open FORCES LIST or BATTLE GROUPS list. In FORCES LIST the organizational structure of the units is shown. It enables control the forces: to select the reinforcement strategies (Table 2.2) and to bring forces from the reserve.

The reinforcement strategy is applied at the end of the player's turn, if the platoon is not encircled. Depending on the strategy, appropriate units from the unit reserves and HQ reserve are selected, which are then added to the platoon composition. The mobility strategy is selected automatically at the start of operation for motor-rifle and motorized infantry platoons. Transport vehicles from the reserve are added in such a way as to be able to transport the entire personnel and towed weapons of the platoon (if possible).

BATTLE GROUPS list shows tactical organization of forces in groups (such formation appears not in all operations). This list allows the reinforcement strategies, as well as battle groups composition. Each battle group consists of several platoons (in contrast to a platoon which consists of units). Depending on the group type, the number and types of platoons can vary (2 to 8 slots). Only a platoon of a given type can be placed in the respective slot. With an exception for company commanders (company command), which can be placed both in the infantry platoon slots, and in the command personnel slots. When you remove a platoon from a BG, it may not be possible to get it back.













Mobility of a BATTLE GROUP is determined by the minimum mobility of its platoons. It may make sense to remove part of platoons from the group (for example, infantry or platoons with broken equipment) in order to increase its mobility.

When choosing a platoon into a BATTLE GROUP, a list of possible replacement options is shown. Platoons from the same battalion are shown on gray background, from the same regiment - on blue, and from other units - on green: attached forces or reserves of the division.

Both lists also show platoons characteristics: condition, logistic support, mobility and ability to attack (Table 2.3), ability to dig trenches, historical background, arrival time, etc.

CASUALTIES AND CAPTURES section lists detailed statistics on casualties and the impact on the enemy for each platoon: personnel losses by type (wounded, heavily wounded and killed, missing), vehicle losses, enemy losses caused by platoon actions, medals awarded and seized captures.

Table 2.3 - Designations in the FORCES LIST

	Able to attack		Not able to attack
	Not able to move		Able to move
	Platoon is digging in		Historical platoon
	Upcoming reserves with individual units		HQ reserve unit or from the reserves
	Is equipped with captured weapons		
	Take from the reserves all platoons of this company		Take this platoon from the reserves and swap with selected
	Replace defeated platoons with a reserve		Set optimal reinforcement strategies

To regulate the game performance in the tactical battle, several options are intended that reduce the number of units that simultaneously enter the battle. There are 3 ways to reduce the number of units in battle:

- 1) "Limit battle radius" - reduces the number of BGs/platoons participating in the battle.
- 2) "Reduce the size of battle groups" - reduces the size of the BG, by reducing the number of platoons included in it (selected through the game difficulty level).
- 3) "Reduce the number of soldiers in the platoons" - there are fewer squads/units in platoons.

You can combine the settings freely to reduce the number of units in battles in these three directions in order to get acceptable performance. Each option has its drawbacks, but it is almost always possible to get a compromise solution.

Also you can always change the radius of the battle (setting 1) during the operation. Therefore, if you do not consider the choice made as suitable and decide that all units need to participate in a particular battle, you can go to the game settings and change the battle radius only for this battle.

In the ORDER OF BATTLE section (in some operations), the command hierarchy for the divisions participating in the operation is shown, and also the neighboring divisions not participating in the operation. By clicking on the division icon in the hierarchy, you can go to the beginning of the list of its platoons or battle groups.

The command hierarchy in tactical combat is based as follows: all units within the battle group are subordinate to the first (on the list) commander located in the battle group, regardless of the actual affiliation of the platoon. For platoons without BGs, the command hierarchy is based on the actual affiliation of the platoon. Within the platoon, the hierarchy is also built from the first (on the list) commander. For company and battalion commanders, a hierarchy is additionally built between BGs, but according to the actual affiliation of the units. The commander of the 1st battalion will command the BGs of the 1st, 2nd and 3rd companies, and the commander of the 2nd will command the 4th, 5th and 6 companies (for the Red Army).

2.1.1 Artillery support

For artillery support in the operation, two types of spotters are used:

- 1) Attached to weapons in the troops list (artillery is presented in the form of units).
- 2) Spotters who control artillery, which is always outside the battlefield (not represented as separate units).

Depending on the level of artillery support (battalion, regimental, divisional, HQ) - the linking is carried out within the battalion, regiment command or batteries of the corresponding divisions for the last two levels, respectively.

For example, battalion mortars will be linked within each battalion, regimental cannons will be linked to spotters within the regiment's command and support units. But the guns from the division's artillery regiment will be linked within their batteries.

For those spotters who are linked to the corresponding guns (1), the actual number of combat-ready guns of a given type is considered. Adjustment and control of artillery fire is possible only for those batteries (guns) that are located in reserve. If the guns from batteries are assigned to a specific battle group, then they cannot control and fire through the spotter.

For both types of spotters (1) and (2), the distance of the gun fire is limited. Firing is possible only if the distance is sufficient for the shells of the gun to reach coordinates in the area of the battle group/platoon to which the spotter is attached. The current distance to the battery guns is displayed in the tip in the corresponding column of the troop list or battle group list.

For battalion artillery, this distance is calculated relative to the center of the battle group to which the spotter is attached - such weapons are always available at a distance. The actual distance of the guns is determined by the number of turns that the battle group was in the same place. The more it is, the closer the battalion artillery is to the actual location of the battle group and, accordingly, the less is the firing distance (but not less than 1 km).

For other artillery (excluding battalion), the distance is calculated relative to the location of the artillery control group (HQ of regiment, artillery regiment, division, corps) to which they belong. But this distance cannot be less than a certain value, which depends on the artillery support level, for example, the HQ artillery are usually located farther than the divisional artillery.

Ammunition for artillery in different operating modes is calculated separately. It is assumed that, for firing from off-map positions through a spotter, ammunition from artillery depots is consumed, and the transportable supply is used only for direct fire or self-defense of the gun.

Support can be selected to each battle group by assigning an artillery spotter. To do this, right-click on the battle group icon and select a spotter from the list, it will be assigned as support to the first battle group commander on the list.

2.2 Start of a tactical battle

Platoons and battle groups can move (depending on their mobility) and attack the enemy in areas of contact.

In the game there are two movement modes for BG/platoons on the operational map, they affect how BG or platoon will attack the enemy.

1) *Direct control*. In this mode attack platoons (tanks, motorized infantry, scouts, and company commanders) can attack at long range, in this case, you can move two squares forward along the line of attack as a result of battle. Such an attack is initiated with **[Ctrl+RMB]**. In this case, the defender has advantage in forces entering the battle.

Attack on one square **[RMB]** is available to any unit (which can attack) and allows to capture 1 square during the battle, while the attacker will have advantage in the number of troops. **Any attack blocks all platoons/BGs that can attack in neighboring nodes relative to the node from which it starts.**

2) *Indirect control*. In this mode, the player gives orders to BG/platoons, and then they move and attack the enemy. If an attack order is given, the BG/platoon will automatically attack the enemy appearing on its way.

A tactical battle occurs when attempting to move to a node occupied by enemy troops, or to a node adjacent to enemy troops, if the overall level of control of the enemy troops in this node is greater than that of the attacker. The level of control depends on the time the platoon/BG is in the node, the general condition and number of units and mobility, and the time of day. The level of control is also influenced by whether the troops were attacked or participated in battle.

Support platoons (guns, ATR, mortars, etc.) and auxiliary platoons (spotters, supply, headquarters, depots, transports and repairers) cannot attack on their own. Also, platoons with characteristics below normal (indicated by a red marker on the map) cannot attack, unless they were not moving for several turns. These platoons are not blocked at the beginning of attack. It is possible to exchange platoons/BG located in neighboring positions. To do this, one (but only one) of the platoons/BG must receive an order to move to a neighboring position.

In the tactical battles phase (after player's and AI's turn) the most important battle is automatically selected. Area and platoons which enter the battle are highlighted. Also highlighted are the direction of attack which led to the battle and nodes which probably cannot be captured (black squares). The possibility of capturing such marked nodes will be determined after the battle, if the node is empty, then it can also be captured.

Click **[LMB]** on the highlighted area starts the tactical battle phase in the 3D mode. If the attack is successful and the enemy squares are captured as a result of the battle - attacking platoons move into the captured squares automatically.

In direct control mode, platoons/BG that did not move nor attack are digging trenches. In indirect control mode, only platoons/BG assigned with the defense order are digging trenches.

Defeated platoons marked by a black marker are disbanded before the beginning of tactical battles.

Platoons/BG under AI control can move out of the reserve squares into the territory controlled by the player forces, forcing them out. This occurs if the total power of the AI forces exceeds the power of player forces in the square they want to move to. However, the presence of defenses is taken into account for the player forces. Forced out player forces move to neighboring squares. Typically, locations of mass ingress of the AI forces are indicated in the briefing, and correspond to those where this happened in the real battles.

BG/platoons can be blocked at the deployment stage before the beginning of the battle if they were:

- ambushed;
- moved more than 1 square on the operational map and got into a battle;
- moved and were attacked by the enemy, but did not attack themselves.

In this case, the BG/platoon units deploy near their location on the operational map (within a radius of about 250 meters) oriented to the nearest enemy key point. Infantry and armored vehicles are in platoon columns, and artillery and support units are deployed in line. Recon units are not blocked. If there is a reconnaissance platoon in the BG, this BG is not blocked.

2.3 Logistics

Ammo replenishment and reinforcement of forces occurs at the beginning of each turn automatically. Replenishment is carried out according to logistic lines, which are shown when headquarters, supply trucks, depots, repair crews or draft platoons are selected. Logistic lines are indicated by circles of different colors, depending on the supply intensity (from green to red in descending order). The outer yellow circle (square) indicates capability of fuel replenishment. **The supply range is affected by the condition of the battlefield surface, weather conditions and time of day, as well as the availability of the road network. The presence of the enemy near supply lines also has a significant impact. Thus, in bad weather at night, outside the road network, supply lines can be significantly reduced.**

Only platoons and battlegroups under headquarters command, or in the same unit (for supply trucks and depots) are replenished. Platoons and battle groups that can be replenished are marked with circles (squares) of blue color, when a headquarters, supply truck or depot is selected.

Headquarters can supply ammo and fuel while being located in the reserve squares, other platoon types must be located in the active zone. Green dashed lines indicate the fact of supply or reinforcement. Repair units take equipment for repair, and then return it to the original platoon. Draft platoons are disbanded after depletion of personnel.

Light damages of vehicles and heavy weapons can be repaired by the crew. Units that have lost their combat capability, but which retained the personnel transfer to the reinforcement category, and their personnel are distributed within the unit.

Each unit may have a reserve of personnel (indicated in the unit table), which is formed from broken and disbanded platoons. Replacement of personnel from this reserve is conducted primarily by means of the unit headquarters.

Battle group may receive an order to disband during the player turn if it is not encircled. For this, click **[RMB]** on the battlegroup icon and select the appropriate option in the menu. The order will be executed after the end of the player turn, if the group was not attacked. When a group is disbanded, platoons comprising it will return to the reserve. Disband order can be canceled in the same way as it was given. It makes sense to disband battle groups which have lost combat value and not having reserves.

A platoon can be disbanded if it is in the reserve and its characteristics are decreased (such platoons are marked in red in the table). To issue an order for disbandment, click **[RMB]** on the platoon icon, a second click will cancel the order. Disbanding platoon cannot be placed in a battlegroup, disbandment will take place after the end of the player turn. Operational vehicles and infantry squads having more than 25% of combat strength will be sent to the reserve. Remaining squads and crews will be transferred to the reserve of the unit personnel.

Disbandment of platoons and BG is irrevocable!

Squad or crew experience decreases when reinforcing personnel, resulting from a decrease in squad coherence when changing its composition. However, the more new soldiers go into a squad, the more experience is reduced (up to -50% for one replacement). Though, experience does not decrease below 25%, if it was not initially lower.

2.4 Special actions

In some operations battlegroups can carry out special actions aimed at disorganizing the enemy forces, as well as increasing the level of personnel training and its condition.

Extended supply lines - for some units supply lines have a long length based on a more efficient logistics system.

Air supply - for some units a forward supply base can be organized by transferring ammunition and fuel by air (helicopters or airplanes).

Mobilization - commanders of the partisan and national-liberation movement units can conduct mobilization of local population from neighboring settlements and villages. Mobilization allows replenishing personnel losses within the battalion to which the commander belongs; to do this he must be located near a village or directly in it. Mobilization is carried out once a day, during the daytime.

Noise generators - some units have special noise generators in their service, which allow to reduce the morale of badly trained enemy troops located near this unit. Noise generators work each turn, but they only affect the enemy at night or in a forest.

Disinformation - a number of headquarters and command units have special departments that deal with the enemy's disinformation, which can significantly weaken a number of its units with low combat capability in successful cases. Thus, the enemy soldiers desert, leaving their units. Disinformation is sent once a day.

Agitation - some units can conduct agitation of the enemy soldiers from nearby units and win over them. Agitation is conducted during the daytime, several times a day. Agitation is aimed at the enemy troops having some training. The effect is similar to the disinformation action, but some of the enemy soldiers can go over to the agitators' side.

Instructors and advisers - there are foreign instructors and advisers in some units, which increase the level of training and morale of the troops. For this purpose training is conducted, in the daytime (up to 2 times a day). To conduct training, unit personnel should not move, participate in battles or dig trenches. Training is conducted in all units located near instructors (instructors are usually located in the command of companies and battalions).

Diversion - some special (usually recon) units can conduct diversions on the enemy facilities and communications, which causes loss of the enemy material and equipment. Enemy vehicles can be blown up by a charge on the move. Diversions are more effective at night or during bad weather. Diversions can be carried out not more often than once a day, in the operating zone of the unit.

Air illuminating bombs - are used at night to interfere with the normal rest of the enemy personnel, which leads to fatigue.

Air supremacy - some sides of conflicts had an obvious advantage in air support, because of airfields located near combat areas and functionally more advanced attack aircraft. Thus, enabling them to seize supremacy in the air during hostilities, blocking the enemy aviation activity.

Use of transport aircraft as ersatz-bombers - transport aircraft were used as bombers in some cases with weak enemy air defense in the combat area. The bombing effectiveness was low, and mostly they had a moral impact on the enemy.

Almost all special actions are performed automatically, the player only needs to ensure the conditions for their use (for example, to place forces in close proximity to enemy or allied forces, or near settlements). Most special actions are typical for modern conflicts (second half of the XX century).

3 TACTICAL MODE

Tactical mode consists of the following phases: deployment, initial orders, combat and after battle statistics. To quickly select platoons a special panel at the bottom of the screen is used (Fig.3.1), special abilities of platoons and squads are shown in Table 3.1.







Fig. 3.1 - Quick selection panel

1) Name (number) of platoon commander	2) Platoon capabilities: AT, smoke, spotters
3) Tactical symbol of platoon	4) Platoon strength (proportional to the number and combat ability of squads)
5) Platoon list scrolling button	

[LMB] click makes a platoon active selecting the 1st unit of platoon in the deployment phase and all combat units during the battle. Second **[LMB]** click selects all combat ready units in platoon. **[RMB]** click moves the camera to the most senior active commander in the platoon without selecting him. **[Ctrl]+[LMB]** click adds units of platoon to the selected.

Units comprising the selected on the panel platoon are displayed in the bottom. Color of the unit's icon indicates its overall condition: black, red (cannot control territory), gray - in degradation order. State of the unit's heavy weapons (if any) is indicated by a colored small square. Red background indicates that the unit has lost combat capability. Number of combat ready soldiers (+crew) and what the unit is currently doing or its condition, if it is different from the norm, are shown on the units panel. '>' sign indicates that the first (main) section **[Alt]** or the second (auxiliary) section **[Shift]** is selected.

Table 3.1 - Special parameters of platoons and squads

	Platoon has an air spotter		Effective AT means are available
	Platoon has a forward artillery observer		AT means are available
	Smoke is available		

There are 4 modes of displaying of unit's markers in battle: only selected units, all units, squads (sections), platoons. The squads (sections) mode is always forced in the initial deployment mode. The show all units mode is always enabled in the statistics mode. During the battle, the player can select the desired display mode with **[F6]** or the corresponding button in the interface. However, the squad and platoon modes are mutually exclusive, the platoon display mode is activated if more than 5 platoons are under the player control. **[RMB]** click on the marker display mode switching button turns off markers (switch to the only selected units displaying mode) or, if they are already turned off - turn on the squads/platoons mode.

When platoon markers are turned on, the player can also select squads (sections), select a platoon, and then click on the squad or section of interest from this platoon. Also, an individual section or squad can be selected in the squad quick selection panel.

3.1 Deployment phase

Deployment mode interface is shown in Fig.3.2-3.3.

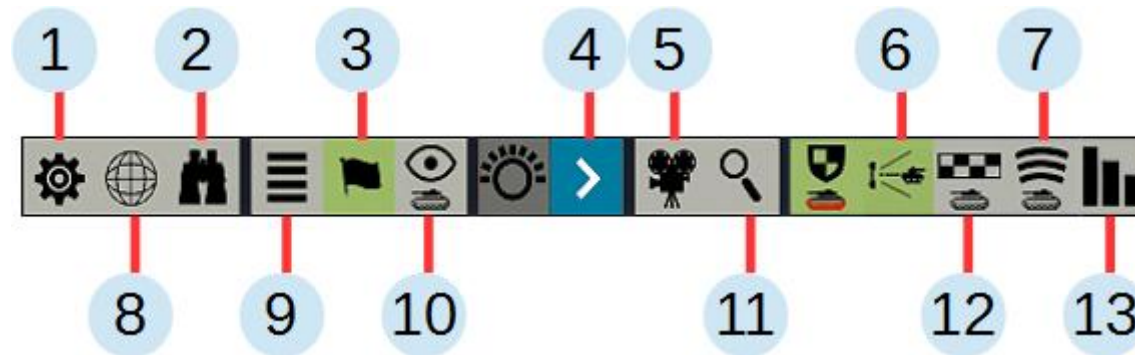

Fig. 3.2 - Unit deployment mode interface

1) In-game menu [Esc] (Table 3.2)	2) Binocular mode [Tab]
3) Show key points [F5]	4) Finish deployment [Enter]
5) Lock camera on selected unit [Q]	6) Show sight sectors [{]
7) Show area of sight [Ctrl+~]	8) Switch to map [F10]
9) List of displayed information [F8] (Table 3.3)	10) Visibility map type: tank, soldier standing, soldier lying [F2]
11) Find and jump to selected unit [Ctrl+F]	12) Show line of fire [~]
13) Show firing capabilities of the selected squads and vehicles [Ctrl+']	

Table 3.2 - In-game menu interface elements **[Esc]**











	Back to game [Esc]		Return to operation (only for battles from an operation)
	Redefine controls		Return to main menu
	Withdrawal		Restore default movement orders settings
	Restart battle		Save battle state before exiting
	Exit game		Return to after battle statistics [Esc]

Table 3.3 - Information display control **[F8]**

Directions	Indicate the direction of every unit
Compass	Show cardinal direction marks above the horizon line
Command hierarchy	Display the command hierarchy using moving arrows
Orders cost	Show the cost of each order on the interface buttons
Paths	Display paths from given movement orders and control points
Paths and orders	Display the same as above, and, additionally, direction on the current target and current movement point for each unit
Fire tasks	Show all fire tasks of every spotter using small crosses
Countdown	Show time until the battle end, instead of absolute time
Fire sectors	Show designated fire sectors for all units, not just selected

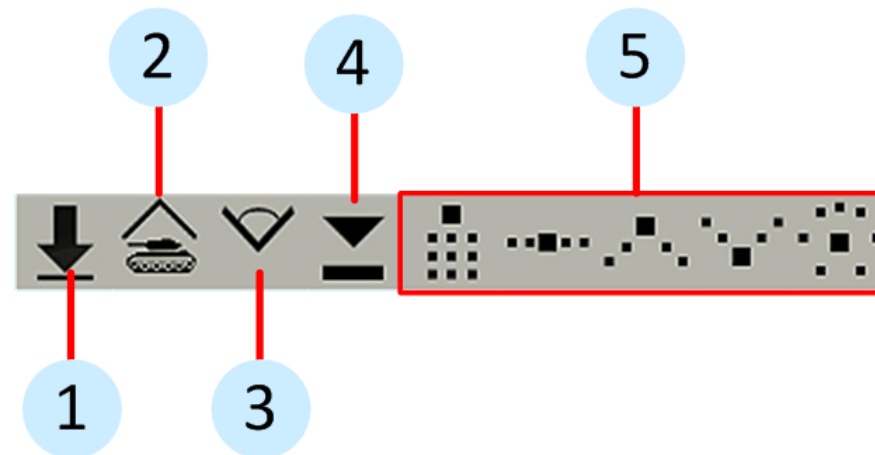

Fig. 3.3 - Unit deployment control

1) Deploy automatically in main square **[X]**

1) Deploy in defense **[N]** in such way that there is maximal range of visibility in the given direction, and on the sides and rear - minimal

3) Set fire sector **[V]**, **[RMB]** - sets default sectors, or cancels sector if it is set

4) Manual deployment mode: movement **[M]** or rotation **[R]**

5) Deploy in several formations **[I]**, **[U]**, **[P]**, **[Ctrl+P]**, **[O]**

In the deployment phase the area available for the placement of all forces is marked by squares of different color. **For the selected platoon, the boundaries within which its units can be placed are displayed.** Blue squares mark locations where the enemy forces will be placed.

The color of the inner contour of a square shows the integral level of concealment in this location: gray - completely open, red and orange - partial, yellow and green - good.

The color of the outer contour of a square shows the possibility of placement and digging trenches: gray - any unit can be placed and a trench can be dug, orange - any unit can be placed, but no trench can be dug, and red - only infantry units can be placed (without heavy weapons). If a square is not marked, no unit of any type can be placed in this location.

Blue ticks between the outer and inner contours of a square indicate how far a target of the selected type can be seen in a given direction: 100, 500, 1000 and more than 1000 meters. Target type is switched with the **[F2]** button.

Units on the defensive can dig trenches prior to a battle. All units can use the trenches left from previous battles. Infantry units can "adapt" to any type of trenches. Vehicles and heavy weapons can be placed in trenches of a suitable type, while changing their direction. For this, the unit must be placed in a square under which there is a trench. Trench marks from previous battles are shown on the map during the placement.

If a unit had dug trenches before a battle, then the entrenchment attribute is reset in the operational phase, and it can dig the next trenches after one turn if it is still on the defensive.

3.2 Initial orders and tactical battle phase

Initial orders and tactical battle phase interface is in Fig.3.4-3.5. Movement orders in the initial orders phase can be given without restrictions.

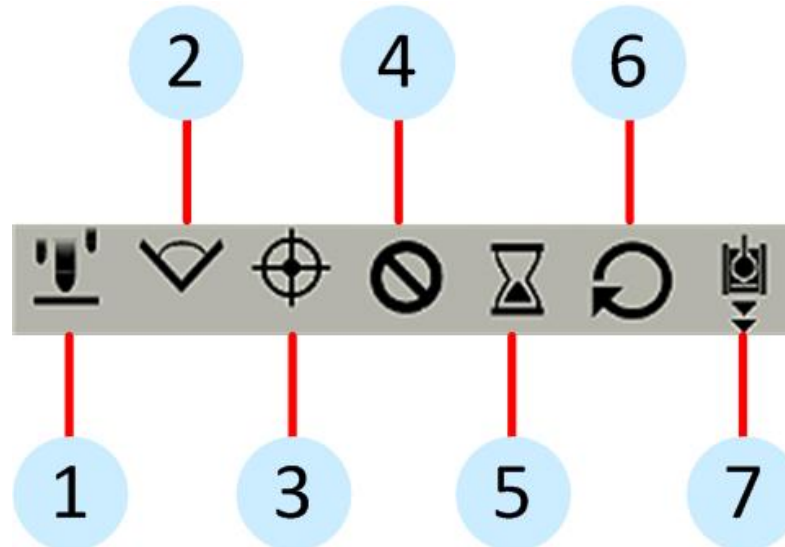

Fig. 3.4 - Instant orders and open fire orders

1) Commander observed fire [G]	2) Fire sector [V] ([RMB] - set default sector or cancel sector)
3) Set priority targets [T]	4) Halt and cancel orders [X]
5) Set delay [B]	6) Turn [R]
7) Reversal [Y]	

Conducting fire with a fire sector set **[V]** has the following specifics:

- if conducting fire is on hold, units will fire only at priority targets within the sector.
- if conducting fire is allowed, units will fire only at targets inside the sector, or priority targets.

Regardless, fire will be conducted at targets located closer than 75 (25 for small arms) meters. Holding fire and limiting the sector does not apply to throwing weapons: explosives, grenades, incendiary bottles, etc.

3.2.1 System of orders and specifics of their execution. Movement orders (Fig. 3.5, Table 3.4-3.5) are given by clicking **[RMB]** on the map or on terrain in 3D view, or by pressing **[Space]** button when setting a chain of orders.

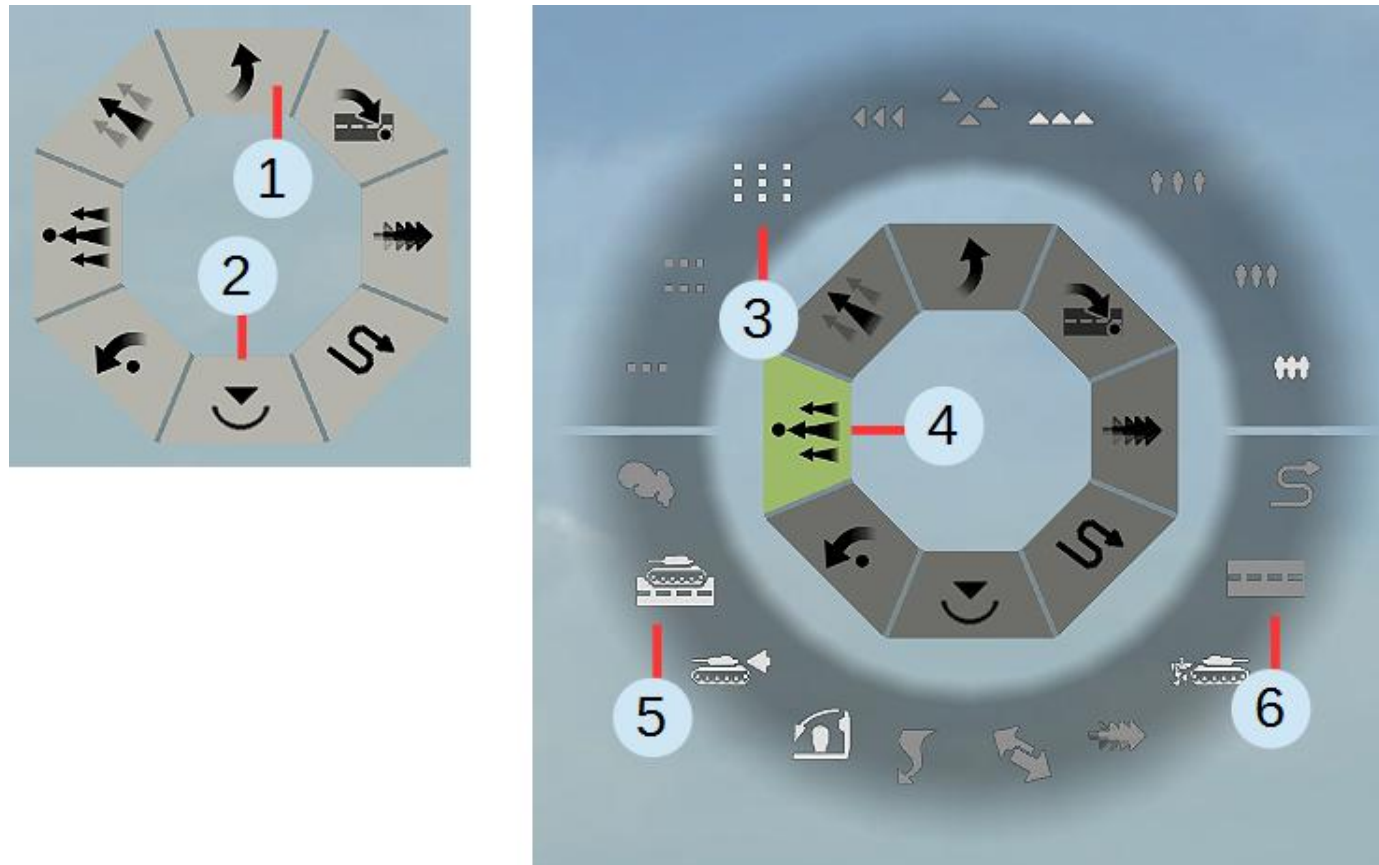









Fig. 3.5 - Movement orders and their modifiers (shown by clicking **[RMB]**)

1) Movement orders	2) Defense order
3) Formation geometry control	4) Modified order
5) Active modifier	6) Inactive modifier

















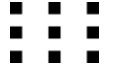

Orders which will not function (or will not function properly for the selected formation) are indicated by blue color, red color in edit mode indicates incorrect modifiers.

Table 3.4 - Default orders

	Move	Column, 3 lines, medium density
	March	Column, 3 lines, high density. Fast move by road, tanks in front
	Fast move	Column, fast move, tanks in front
	Covert move	Column, 1 line, medium density. Move covertly and fast
	Recon	Line, 1 row, medium density. Move fast, active maneuver, interrupt order after contact with enemy
	Assault	Line, 1 row, high density. Buttoned. Troops move in groups behind vehicles
	Attack	Line, 1 row, medium density. Tanks in front, active maneuver, buttoned, set smoke screen
	Take defense	Fast move without formation, find cover at the end of path

Each of the orders can be modified, the changes are saved in the player profile.

Table 3.5 - Movement and formation modifiers

	No formation		Dense formation
	Column		Normal formation
	Line		Sparse formation
	In 1 line		In 3 lines
	In 2 lines		
	Tanks in front		Move behind vehicles. If the modifier "tanks in front" - will be only behind tanks
	By road		Vehicles by road (if possible)
	Select a covert route for movement		Fast move
	Actively maneuver when moving (in attack)		Cancel order if enemy is spotted
	Button up and turn off the lights		Smoke

When moving in line (wedge), units try to keep formation while ignoring some of the obstacles on their way. If an absolutely impassable obstacle is in the way of unit movement, the unit will break formation and will seek path independently. For movement in such formation prefer flat terrain without significant obstacles (fields, meadows).

When moving in column, the leading unit will make a path and the rest will follow it, in most cases this formation type will allow for a more optimal path, without obstacles. However, if units of different types (vehicles, tanks, soldiers) are moving in the column, their paths may differ on rough terrain, for example, when making a heavy grade infantry could move straight forward, but vehicles would seek the least sloped place. This applies especially when overcoming various obstacles.

If the covert movement modifier is enabled, units will move in low grounds and terrain areas masked by environment features ignoring most of the obstacles. Usually such areas are only partially passable for vehicles, and using this modifier for vehicles can lead to a bogging down. This modifier is automatically disabled if line formation is used.









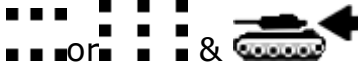
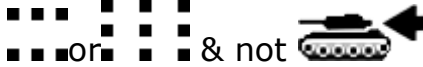

The movement by road modifier (vehicles by road) is preferably used when it is necessary to move over long distances or in tough terrain conditions (gullies, forests, rivers, etc.). Movement by roads minimizes the risk of vehicles bogging down and fatigues soldiers less.

The active maneuver modifier allows units to maneuver (break formation) when in contact with the enemy, and also actively search for targets on the battlefield. However, maneuvering increases the risk of bogging down, and so it is advisable to use it when moving in line on flat terrain without significant obstacles.

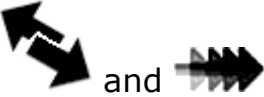
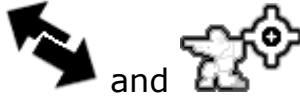
Smoke screening is reasonable to use when the probability of contact with an enemy is high, in this case some infantrymen or vehicles will move ahead of formation and place a smoke screen (if smoke ammunition is available).

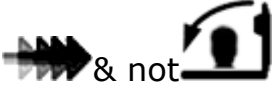
Remember that unit movement is strongly influenced by weather conditions and terrain, in bad weather (rain, snow) part of the area may become impassable, for example, steep climbs, marshy lowlands.

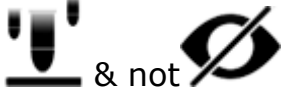
Table 3.5 (continued) - Mutual influence of modifiers and modes

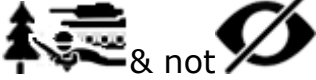
	Run while no enemy is seen, then crawl		Crawl and remove mines if possible
	Move in double wedge, tanks in front SPG behind		Move in single wedge - tanks and SPG in single line
	Cancel movement order if more than N of the units in the group found dangerous targets		Move in the opposite direction if more than N of units in the group found dangerous targets
	The N value for canceling the order is $\frac{3}{4}$, otherwise $\frac{1}{4}$. When driving in a column $\frac{1}{10}$		Danger from infantry targets is ignored, the order does not cancel if only infantry targets
	Button up and turn off the lights		Turn on the lights for fast movement
	Fire with smoke shells		Fire with shrapnel and HE shells (or machine gun)
	Deploy in any available cover		Deploy only in the specified direction







Game allows orders to be chained using either **[RMB + Shift]** (w/o specific orientation) or **[Space]** (ability to specify orientation). It is possible to give sequenced orders to your troops right after the deployment phase w/o command-level costs and let units do their best to fulfill them in combat.

3.2.2 Autonomous movement of forces. Units can perform some of the actions automatically, without player participation. Such actions can be divided into two groups.

1) Controlled by modifiers - in this case, the player can turn on or off automatic actions with appropriate modifiers (Table 3.6). By default, AI movement control is turned on for infantry and signallers. This lets them automatically maintain communication with the commander, but can cause unwanted maneuvers.

2) Uncontrolled - actions that a unit makes when losing control, for example, after the death of a squad or tank commander.

Table 3.6 - AI control

 &	Fire at will	 & not	Hold fire
	Don't transmit external target designation, fire on external target designation	not 	Do not fire on external target designation, do not observed fire
	Leave trenches, lay wire links, return to commander if control is lost, search for cover when under fire or enemy is approaching	not 	Do not leave trenches, do not lay wire links, do not return to commander if control is lost, do not leave positions

The following types of uncontrolled actions can be distinguished:

1) Unit withdraws to a safe area (to the allied forces) - this happens when a unit's combat ability is lost, for example if a tank gun is damaged, or lack of crew for normal operation.

Conditions of occurrence:

- no commander (nor external command);
- the unit has insufficient experience (less than 40 points);

- the unit has an average experience (40-70 points), but the command level is less than 50.

2) Heavy weapon crews abandon it if ammo has run out and the enemy is in the immediate vicinity (less than 200 meters).

3) Vehicle is damaged and has lost combat ability (crew is killed, turret mechanisms or gun are damaged, or has lost mobility) - vehicle crews leave it and search for cover in the range of 50-100 meters from it.

4) Panic - units stop responding to orders, cease fire and sometimes abandon positions.

Conditions of occurrence:

- heavy firing;

- low morale;

- lack of control (no commander).

5) Attack of the enemy - unit closes in to the enemy for throwing a grenade or inflicting damage by other weapon types (only for units of allied AI and enemy!). Occurs in some units, when spotting a single enemy unit and having high morale.

6) Mine clearance (only for units of allied AI and the enemy!), if there is suspicion of presence of mines in the location of a battle group, which has units capable of mine sweeping (experience over 70 or combat engineer units), these units clear column routes for vehicles that move after them.

3.2.3 Abandoning knocked out vehicles. Crews abandoned vehicles and heavy weapons when the following conditions occur:

- 1) Vehicle cannot fire from the main weapon and move.
- 2) Fire broke out in the driving compartment.
- 3) One of the key crew members is killed (gunner, commander, driver).

In some cases, vehicles and heavy weapons may be abandoned due to low morale or death of a large number of crew members. Abandoning can occur either quickly - in the event of fire or apparent inoperability of a vehicle, or after a time.

For the enemy, vehicle is considered destroyed with clear signs:

- 1) Abandoning by the crew.
- 2) Ammo detonation.
- 3) Fire, smoke (in some cases).
- 4) Long period of inactivity or clearly noticeable significant damage.

Vehicle will be fired upon, in most cases, until such clear signs appear, even if it is already destroyed or abandoned.

Crews can return to vehicle and to heavy weapons after a time if there is no visible enemy nearby (in 250 m radius) and vehicle or heavy weapons can potentially fire from the main weapon.

3.2.4 Enemy detection and concealment. The visibility of a unit is influenced by a number of factors: its size, movement speed, whether it provides fire, etc. Also visibility depends on the unit location on the landscape and the nature of the terrain in this place. Movement and firing from “dusty” soils significantly expose the unit, and being in dense vegetation or tall grass, on the contrary, contributes to concealment. At night, the influence of smoke and dust generated during movement or firing is reduced, but the visibility of muzzle flashes is significantly increased.

Target detection is affected by the quality of the observation devices, as well as their number. Here, only one crew member can conduct observation in one device at one point in time (when idle). Observation devices may be damaged or completely destroyed. The layout of the observation arc and currently used devices for each unit can be viewed [F5]. The visualization is only for one selected unit. Devices in use are indicated by blue color, observation arc - gray, damaged or destroyed devices - purple and red.

Key combination [Ctrl+~] allows to view the terrain areas which are potentially visible by the selected unit (excluding active devices). Remember that the near field of view of tanks and armored vehicles has significant dead zones.

On the characteristics panel (left) for the unit, there are two parameters specifying the available instruments and observation sights:

1) Observability - indicates how well the unit conducts observation. The assessment is conducted relative to a single person (level 33), a lower value is shown in red. The values from 33 to 99 (visibility of three people) are shown in blue. This parameter indicates the probability (and speed) of target detection from various angles.

2) Quality of the sights and observation devices (if present) - indicates how well the targets can be detected and fired at, depending on the distance to them. Usually this value is proportional to the power and quality of the sights installed on a vehicle. This parameter indicates the speed of detection of distant targets and the accuracy of firing at them.





The visibility of units of small height is significantly influenced by the grass cover in the place where they are. A motionless soldier lying in the thick grass may be practically indistinguishable.

The ability to observe the surrounding area has a significant impact on the zone of control a unit has. The more area the unit observes for a longer range, the higher its zone of control. Captured territory at the end of the battle is calculated depending on the zone of control. Thus, units located in forests, in the middle of villages, in ravines and other areas with limited visibility may have little or no control over the surrounding area.

3.3 Command level

Command level indicator is located at top center, it shows the possibility of orders executed by selected units (Table 3.7), and the time required for their successful issuing. The recovery rate and the initial command level depend on the game settings, as well as the level of commanders on the battlefield.

Table 3.7 - Command level indicator

	Orders will be executed for all		Orders will be executed by part of units. Shows time until all units will be able to execute order (in seconds)
	Orders will not be executed. Shows time until at least one unit will be able to execute order (in seconds)		
	Order has a high "cost"		Order has a low "cost"

Order cost depends only on its type and how many times it has been issued, and does not depend on the number of units it is issued. The cost of every order equals 0 on the initial orders phase. Therefore, the optimum is to issue orders to large groups or to plan tasks on the initial orders phase.

3.3.1 Unit status. Each unit can be in one of states:

1) Default - executes all the player's orders if the command level is sufficient. Acts automatically only within the modifiers enabled by the player.

2) Transition to defense - for units under fire that do not have current tasks. If the AI maneuver control modifier is turned on, there is an observed enemy closer than 500 meters and a significant level of fire, as well as if the unit is not moving and is not in the trench, then a cover position is selected for it in a certain radius from the current position. The unit is sent to the selected cover using the covert movement command. If the enemy is closer than 200 meters, then a cover is sought away from the enemy. Unit switches to this mode only from the "default" mode.

3) Transition to attack - an automatic attack for combat units with high combat readiness that are not on the defensive if the enemy is less than 1 km away and the unit has no active task. The unit begins to move towards the enemy in the attacking formation. The unit may switch to this mode only from the "default" mode if the AI maneuver control modifier is turned on.

4) Broken main weapons (only for vehicles and heavy weapons) - if the main weapon is critically damaged, the unit will automatically disengage and move to a remote key point controlled by the allies. If possible and the driver is competent, it will drive in reverse for some distance, then it will turn around and proceed to the key point in the covert movement mode.

5) Retreat - begins when the unit's combat sustainability drops to 0. The drop in combat sustainability occurs with prolonged enemy influence and/or losses. When retreating, units leave their positions and move in some safe (from their point of view) direction, ignoring the player's/AI orders. After a certain time, the units will take up the defense and become controllable again if the enemy's influence stops.

6) Surrender, as well as retreat, occurs when the combat sustainability drops to 0, if the unit is surrounded by the enemy or most of the soldiers from it cannot move (wounded, contused, pinned down by enemy fire). The likelihood of surrender also increases if the unit runs out of ammunition. Thus, if a unit cannot retreat and there are enemy soldiers nearby, it is highly likely to surrender. If the soldiers surrendered, then they automatically move with their hands up to the nearest key point controlled by the enemy, if there is no shelling. Control of such units is blocked until the end of the battle. After the battle, they listed the unit's irrecoverable losses.

Initially, the unit's combat sustainability depends on the morale and experience, as well as the availability and serviceability of weapons. Combat sustainability is proportional to the time that a unit can withstand under the influence of the enemy. At the same time, the presence of a stable connection with the commander reduces the rate of decline in combat sustainability under enemy fire. But the presence of panicked soldiers with a low level of morale in a unit increases the rate of drop in combat sustainability.

The morale level is affected by the presence of a capable senior commander and reliable communication with him. Command of low morale units is difficult and requires a significant level of command. Try to keep your units cohesive. Do not move units with low morale or low combat sustainability separately from commanders.

3.4 Displaying the information and parameters of the selected units

Selected units information panel is to the left in the center (Table 3.8).

Table 3.8 - Parameters description (vehicle condition)





Symbol	Designation	Comment
	Group type (unit type): transport, artillery, infantry, tanks and SPG, mixed	Number indicates the number of heavy weapons (Weapon condition, % for a single unit)
	Vehicle stuck	Repeated movement order removes this indication
	Vehicle or heavy weapon immobilized	
	Heavy weapon dismantled or not ready to use	For weapons which are dismantled into parts, carried, or rolled
	Vehicle or heavy weapon requires repair of the main armament	

Table 3.8 (continued) - Parameters description (personnel)









Symbol	Designation	Comment
	Personnel	Number of active men (number of unfit for combat)
	Retreat	Personnel is retreating
	Surrendered	
	Completely destroyed	Entire personnel is unfit for combat
	Suppressed by enemy fire, panic	
	Part of personnel is contused	Contused soldiers become combat-ready after a while
	Level of enemy firing	
	The unit is in the local encirclement	If such a unit's combat sustainability becomes equal to 0, then with a high probability it will surrender

Table 3.8 (continued) - Parameters description (personnel parameters)







Symbol	Designation	Comment
	Command level	Determines how well soldiers will obey orders. Blue indicator signifies no link with the superior commander
	Experience	
	Morale and combat sustainability	Shows the relative sustainability in %, as well as the absolute value (for comparing different units)
	Stamina	Soldiers with high fatigue (low stamina) will move slower, reload weapons slower, and also fire less accurately
	Zone of control	The higher value, the more influence the unit has on the capture of territory at the end of the battle
	Average movement speed of formation, km/h	
	Spotters	Such units can control artillery fire or call air support

Table 3.8 (continued) - Parameters description (supplies)







Symbol	Designation	Comment
	Ammunition, % of full ammo load	Detailed list of weapons and its available ammo will be shown when hovering over this icon
	Smoke ammunition	
	Weapon overheating	Red indicator signifies significant overheating, weapon cease firing in this case
	Fuel, % of full tank	
	Observability	Indicates how well a unit is observing. Estimation is done relative to a single person (level 33), a lower value is shown in red. Blue color indicates values from 33 to 99 (observability of three people).
	Sights and observation devices quality	
	Can remove mines	When crawl [Ctrl+G] without the fast move modifier - soldiers search and remove mines.

Table 3.8 (continued) - Parameters description (communication)

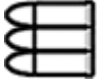









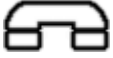



Symbol	Designation	Comment
	Can lay a wire link	
	Can lay a wire link using special vehicle	
	Has signal flares	Can designate targets without established communications
	Wire link can be established	
	Has radio station	Red color indicates half-duplex link, blue - requirement to stop
	Voice communication	Red color indicates limited voice communication ability (under fire)
	Wire link condition	Red color indicates communication break, blue - link is establishing
	Radio link condition	Red color indicates receiving communications only (half-duplex)

Table 3.8 (continued) - Unit behavior

Symbol	Designation	Comment
	Transfer fire control of the unit under AI commander control [Ctrl+O]	
	Transfer the unit under AI control [Ctrl+M]	Laying communication lines, maneuvering, seeking cover
	Cancel targeting [N]	
	Act with caution [Ctrl+G]	The soldiers will lie on the ground. On the movement command soldiers will move crawling. Tankers will work with closed hatches. Dangerous targets will be preferred when firing
	*Prepare ambush after finishing deployment, before the battle [B]	When in concealment mode, soldiers will be positioned in any available cover, and if not - only in the specified direction (houses, trenches or shell holes)
	Fire at will [Ctrl+Y] , at infantry [Ctrl+H] , at aircraft [Ctrl+J]	If on hold fire, units will fire only on priority targets
	Mount (dismount) troops into (from) vehicle [E] , [L]	Mount troops in or on armor and gun towing

*If this option is set, soldiers and vehicles will change their location after the deployment phase!













When several units are selected, the worst value of the parameter for them is shown in the information table. In addition, the number of units from the total number (displayed at the top of the table in square brackets) for which the value of the parameter is specified is shown. Or % of the total number, if the table is in the closed position.

For parameters indicating the behavior of units, and also personnel, the number of people for whom the behavior is set (marked by gray color) is indicated. Behavior not available for the time being for the selected units is not shown.

Average speed indicator shows value in km/h.

Marks about transmission of messages via communication channels: wired, radio, and voice, and also received messages and constraints on message reception and unit's response to messages are shown above units (Table 3.9).

Table 3.9 - Communication system and targeting indication

	Target designated for subordinates from the superior commander (priority target)		Information exchange within squad or vehicle crew
	Target designated for subordinates inside platoon		Received target designation from commander
	Unit executes AI order or is firing on external target designation		Received target designation by wire (or is establishing wire link)
	Unit cannot execute AI order or fire on external target designation (or AI orders are locked)		Received target designation by radio
	Unit is under fire and has limited ability to follow orders		The artillery observer sees shell explosions and adjusts the fire
	Unit has lost control and is returning to the platoon commander		Unit has lost control, but cannot return to the platoon commander (AI control is turned off)

The main types of communication in the game: voice, wire, radio. Additional types: flares, tank phone. Available types of communication are shown in the bottom of the selected units properties panel (to the right).

Voice communication is available to any unit (for closed vehicles it is necessary for the crew to open hatches). The maximum range of this type of communication in the best conditions is ~50 meters for one person. Each soldier in a squad or a crew who is not seated in a vehicle and not controlling heavy weapons (ATR, machine gun, mortar, etc.) can be used as a messenger, which extends the communication range to 100-150 meters, depending on the number of messengers. Range and quality of this type of communication is significantly reduced in combat, which is indicated by the red color of the indicator.

Wire communication is established by signallers (AI control should be enabled for them), from a higher commander to subordinates. In addition, signallers should be a part of the platoon of the higher commander. If a platoon is on the defensive, wire links will be established before battle starts. Signallers move in pairs, covertly whenever possible (not by the shortest distance), thus a single signaller squad can simultaneously lay up to three wire links or repair them. For a wire link to be established it is required that units which it connects would not change their position. Wire links can be broken in intense combat. Wire communication makes it possible to transmit accurate target designation in all conditions. Some types of signallers have special equipment or vehicles in service, in this case, one channel is laid using a vehicle.

Radio communication is typically used for vehicle and tank communication (sometimes portable radio sets are encountered). In addition, radio communication can be bidirectional or unidirectional (from commander to subordinates) - the connection type indicator will be red. Also, there are radio stations which only work if the vehicle is stationary (or their range is reduced when moving).

Main types of communication require both units, between which a connection is being established, to support the same type of communication. That is, for radio communication two units must have a radio station, for wire communication between units a wire link must have been laid, for voice communication units should not be located in a closed vehicle and should be close to each other.

Signal flares - allow to give a rough target designation on the enemy (draw attention of allies), and usually each commander has them. In the daytime smoke signals are used, and at nighttime - flares of different colors.

Tank phone enables communication of a tank and nearby infantry, in this case the crew does not open hatches and climb out of them.

Communication is the most important factor influencing the control of troops. Units left without communication with the commander can no longer be controlled, or require a high command level for complying

with orders (see Section 3.3). Also, commander use main types of communication to support the morale of subordinates, not allowing them to panic and surrender when suffering losses or under fire. The command level is transmitted both from commander to subordinates, and within platoon from unit to unit, or between platoons, if they are within the voice communication range.

Also, communication channels are used for transmission of target designations, for example, from a spotter (forward observer) to the firing assets. Typical layout of target designation transmission consists of an observer connected using wire (or voice) link with the battery commander. Which in turn is connected using a wire link with the firing platoon commander, which designates targets for battery guns or mortars using voice.

If commander control is lost, units with AI control enabled will try to regain control, automatically moving into the commander's voice communication radius, if they are not in trenches, or have not received a movement order.

Table 3.10 - Color indication for unit markers (default)

Enemy markers			
Yellow	Has been visible and recognized, but currently is not visible	Light-yellow	Has been visible and recognized, but currently is not visible by selected units
Blue*	Visible and recognized	White	Visible and recognized by selected units
Gray	Destroyed, abandoned or non-combat-ready		
Player and allied markers			
Red*	Player unit	Orange*	Allied unit
Purple**	Selected player unit	Yellow blinking	Having problems (no ammo, weapons not functioning, not enough crew for operating, no commander)
Light-red (orange) blinking	Under fire	White blinking	Under heavy fire
Black blinking	Lost control (panic, not enough command level)	Gray blinking	On hold fire

*Color for the default layout, if the layout is changed in the settings - colors will be different

**Assigned in the settings

Messages and groups combined by an order panel are to the right in the center (Table 3.11). Clicking **[LMB]** allows you to jump to the message or select the group. Right-clicking allows you to jump to the unit with which the message is associated. To select the unit associated with the message, you need to click with hold down **[Ctrl]**.

Table 3.11 - Messages from allied forces







Symbol	Designation	Comment
	Contact	Allied forces spotted enemy forces moving
	Under fire	Allied forces are under enemy fire
	Message	
	Wire link	Wire link is established or broken
	Retreat	Allied forces left their positions and retreat
	Capture	Allied forces surrendered
	Commander killed	

Table 3.11 (continued) - Messages about heavy weapon and vehicle condition













Symbol	Designation	Comment
	Bogged down	Vehicle bogged down
	Main weapon broken	
	Vehicle abandoned	Heavy weapon or vehicle are abandoned by crew or destroyed
	Vehicle crewed	Vehicle or heavy weapon were crewed
	Group order	After a movement order is issued to any group, its icon is placed on the message panel. Click on the group icon to quickly select it.

Table 3.11 (continued) - Events

Symbol	Designation	Comment
	Point capture	Key point was captured (or lost)
	Airstrike	Airstrike begins - aircraft is over the battlefield
	Artillery strike	Artillery strike begins - battery is opening fire on the specified fire line
	Cease fire	Enemy offered cease fire, the offer will be accepted after pressing this button
	Continue battle	Enemy rejected a ceasefire offer
	New objective	
	Objective accomplished	
	Objective failed, timeout	Objective failed, or time allotted for objective is over, but objective still has not been accomplished

3.5 Air and artillery support

Air and artillery support control panel is also to the right in the center (Table 3.12), when such support is available. For the support to be available you need to take an air or artillery spotter into battle (in a quick battle it is selected with the reinforcement strategy - reinforced support). In operation, in most cases, aviation arrives according to the scenario.

Table 3.12 - Types of support and fire control

















	Battalion artillery (usually always available)		Regimental artillery
	Divisional artillery		HQ reserve or detached arty regiment artillery (available only at the planning stage)
	Air support, called automatically (except tactical UAV)		Battery can be controlled only at the planning stage
	The line at which fire will be or is delivered		Reference point, which will be zeroed on, and will be used for a quick call for fire later on
	Delay time of commencement of fire relative to current		Add new fire task

Table 3.12 (continued) - Parameters used for setting up a fire task

	High-explosive shells, can operate in two modes: with delay for blast or for splinter (immediate) effect		Shrapnel shells, can operate in two modes: on impact (immediate action) and airburst
	Smoke shells		Incendiary shells
	Flare shells		
	Set fuze for immediate action (for high-explosive and shrapnel shells)		Shells per gun: 3, 5, 15 ... all

Artillery control is divided into two parts: planning (in the deployment stage) and unscheduled support, during a battle. Depending on the availability of commanders and combat conditions, various types of artillery can be used both at the planning stage and during a battle. Herein, any kind of artillery can be used at the planning stage, but during a battle - all types, except HQ reserve or detached arty regiment artillery. Presence of a battalion or regiment commander in a battle enables use of all types of artillery, including divisional, during a battle. Presence of a company commander enables the use of regimental artillery. Battalion artillery can be used at all times. Use of artillery in a battle may be restricted in some operations.

Artillery control is achieved by setting up a list of fire tasks, each of which is executed immediately (if the battery is free) or on schedule. For artillery controlled during a battle, reference points can be zeroed on. To do this, they must be set as fire tasks during planning, selecting fire intensity - "Zero in". After such a task will be completed by the battery, a reference point (indicated by an orange triangle) will be added for this battery. Adding a fire task during a battle, next to the reference point, increases accuracy and reduces the time needed to open fire.

To indicate the location of a fire task, an "artillery cursor" is used - a special mark on the map or in 3D view that indicates the width of the field of fire, the approximate accuracy (in meters), and the time to commencement

of fire. The fire can be proceed in concentratedly at the selected target, then all the guns will be aimed at one point, or in a fan, then the guns will fire at targets located at a certain interval on the firing range, but within the general assigned firing mission.

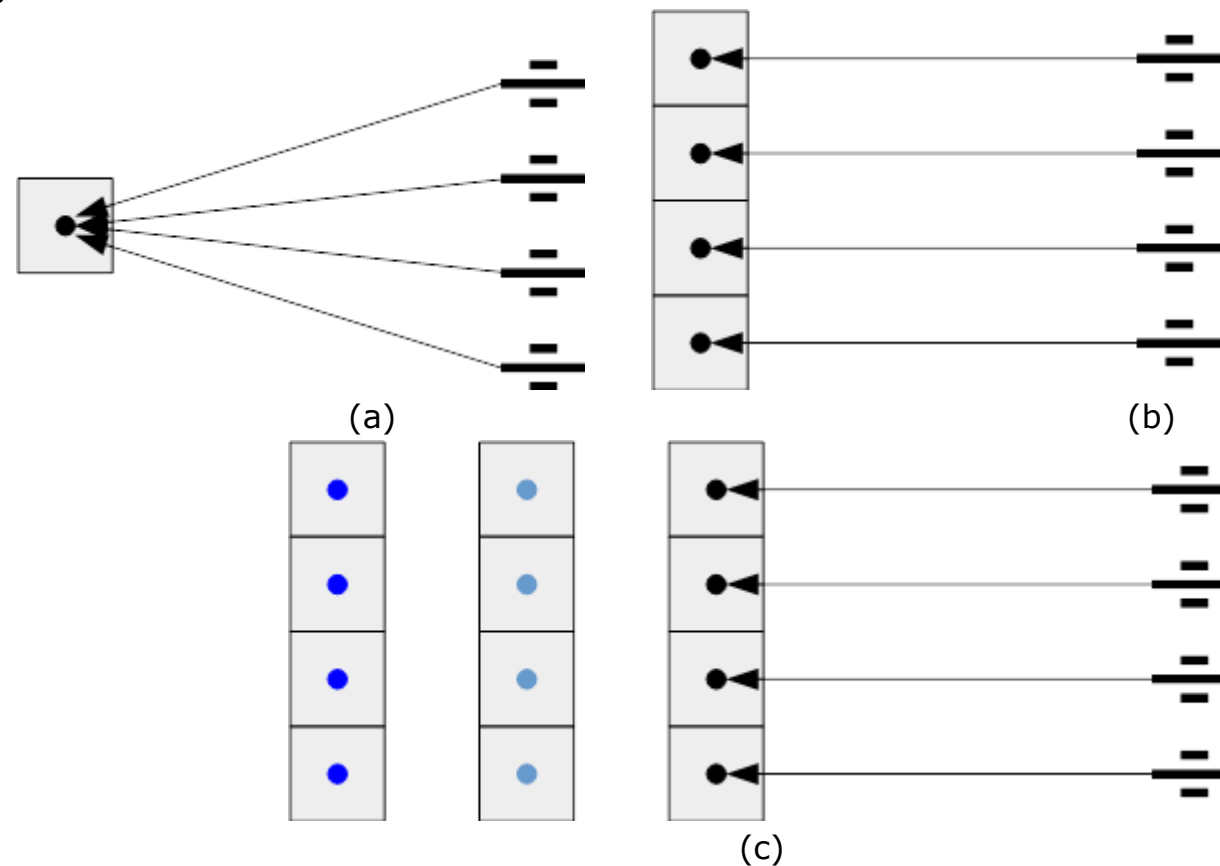

Artillery battery aiming types:
 a) concentrated fire b) shooting with a fan c) movable fire

The firing mission can be "dynamic", i.e. the line along which the fire is being proceeded will move over time after 5 shots. To do this, it is necessary to extend the "artillery cursor" in a direction parallel to the direction of the battery for more than 50m (a step of changing the line). Points of subsequent frontiers will be marked with blue shades of color.

Also, for each task an absolute time of commencement of fire (relative to the current game time) can be set, which enables scheduled artillery strikes throughout the entire battle. The tasks in the list are sorted according to the time set, each following task begins when two conditions are fulfilled: the battery has completed the previous tasks, the time set when adding the task has come.

Adjustment and adding of fire tasks during a battle becomes impossible if the spotter's commander is killed or put out of action. If the spotter is combat-ready and observes the explosions of the battery shells, then it corrects the accuracy of firing. After the accuracy reaches a certain value, the battery switches to maximum rate of fire. It should be remembered that the rate of fire decreases over time, i.e. the battery cannot fire at maximum intensity for a long time. For short fire missions (less than 5 rounds per gun), fire proceeds at the maximum rate. For continuous fire missions, the rate is initially lower.

The maximum technical rate of fire at full charge for various Soviet artillery systems is shown in the figure below.

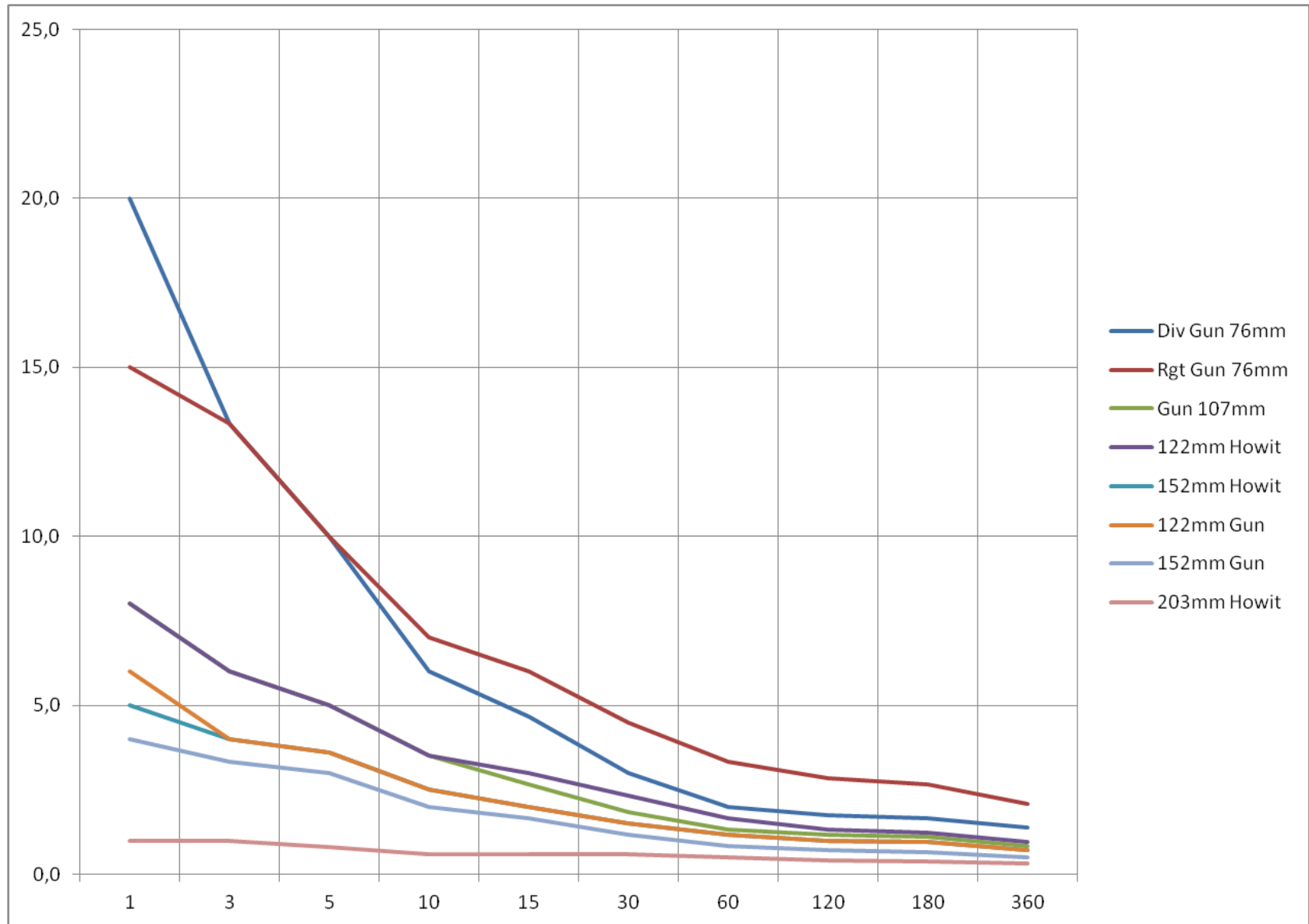

The maximum technical rate of fire at full charge for various Soviet artillery systems

3.6 Tactical diagrams and armor penetration charts

A pair (unit and weapon) is required for displaying tactical diagrams and armor penetration charts in a tactical battle. In game: select a unit, it should have a target (orange line). Or second option, select a unit and point at a visible target in the line of fire mode [~]. In figure the pair is KV-1S (diagram is drawn for it) and Pak-38 gun. Diagrams and charts are shown by using the [}] button.



Vertical portion - armor penetration chart similar to the one shown in the encyclopedia (chapter 5.2), level of armor penetration is shown vertically, distance - horizontally. Horizontal blue line indicates the armor level of the projection from the direction of the target for the selected part of the vehicle (lower hull, top hull, turret). The example in the figure shows the top hull selected. To toggle the vehicle part click **[RMB]** on the tactical diagram toggle button. Broken lines indicate the level of armor penetration for gun projectiles (yellow line - APCR, red - armor-piercing).

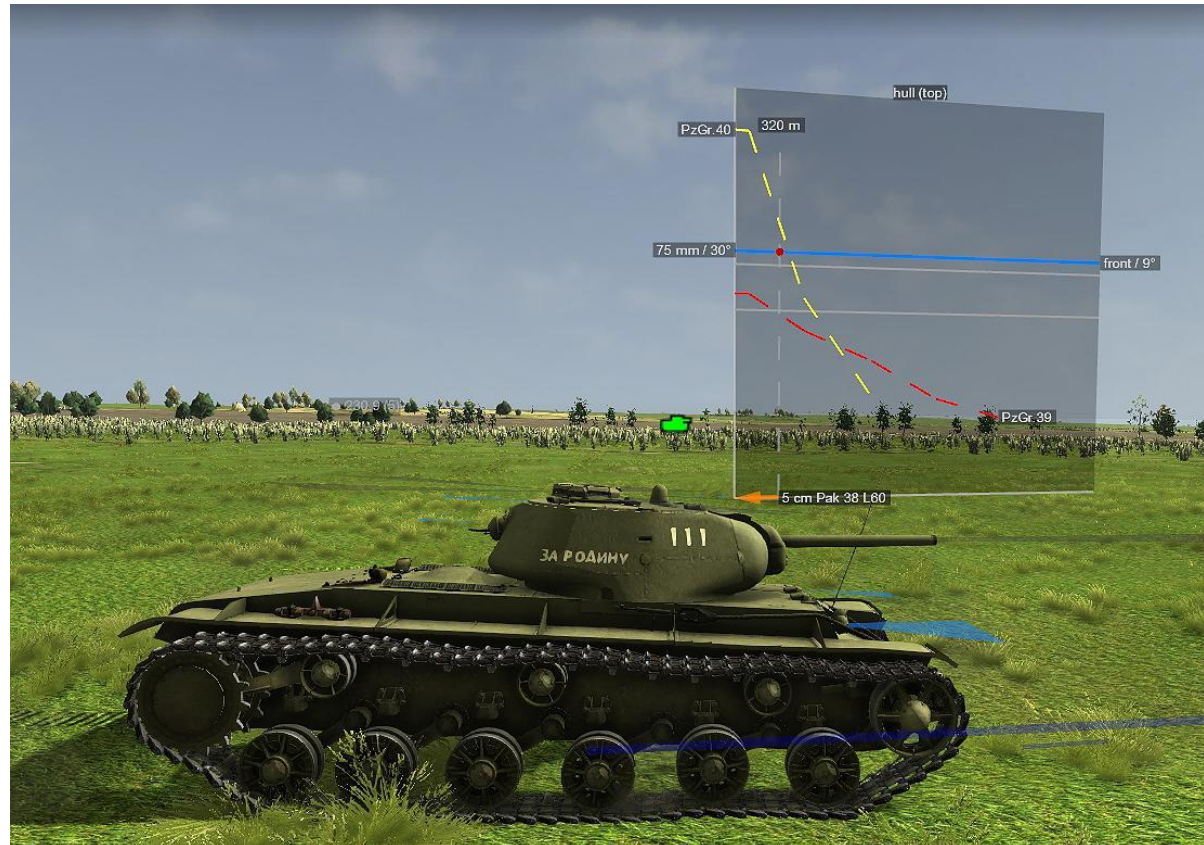

Orange arrow indicates the distance to the gun - 320 m. Red dot - indicates current position of the selected tank part in the coordinate system of the chart. If the red dot is below the broken line, the projectile indicated by the line penetrates the selected vehicle part from the given angle and distance. Figure shows that PzGr.40 projectile penetrates from this distance, but PzGr.39 projectile - does not.

Horizontal portion is the tactical diagram. It shows from what distance and what angle the gun projectiles penetrate the selected vehicle part. The distance axis is along gray lines, represented by tear-shaped curves in each quadrant (front, rear, left, right). Each tick mark corresponds to 100 meters distance. Yellow and red lines indicate the distances of armor penetration for two types of gun projectiles (colors are similar to the armor penetration chart).



Orange arrow indicates the position of the gun. If the blunt end of the arrow is located inside the closed line, then the gun penetrates the selected vehicle part with this projectile from a current angle. The figure shows that

only the PzGr.40 projectile (yellow color) is able to reliably penetrate the front and rear. And sides can be penetrated by two projectiles (PzGr.40 - from 700 m, PzGr.39 - from 500 m). If the arrow becomes blue, it means a high probability of penetration.

The chart and diagram are connected to each other along the axis indicated by the orange arrow - the "ideal" direction from which the gun projectiles will hit the tank.

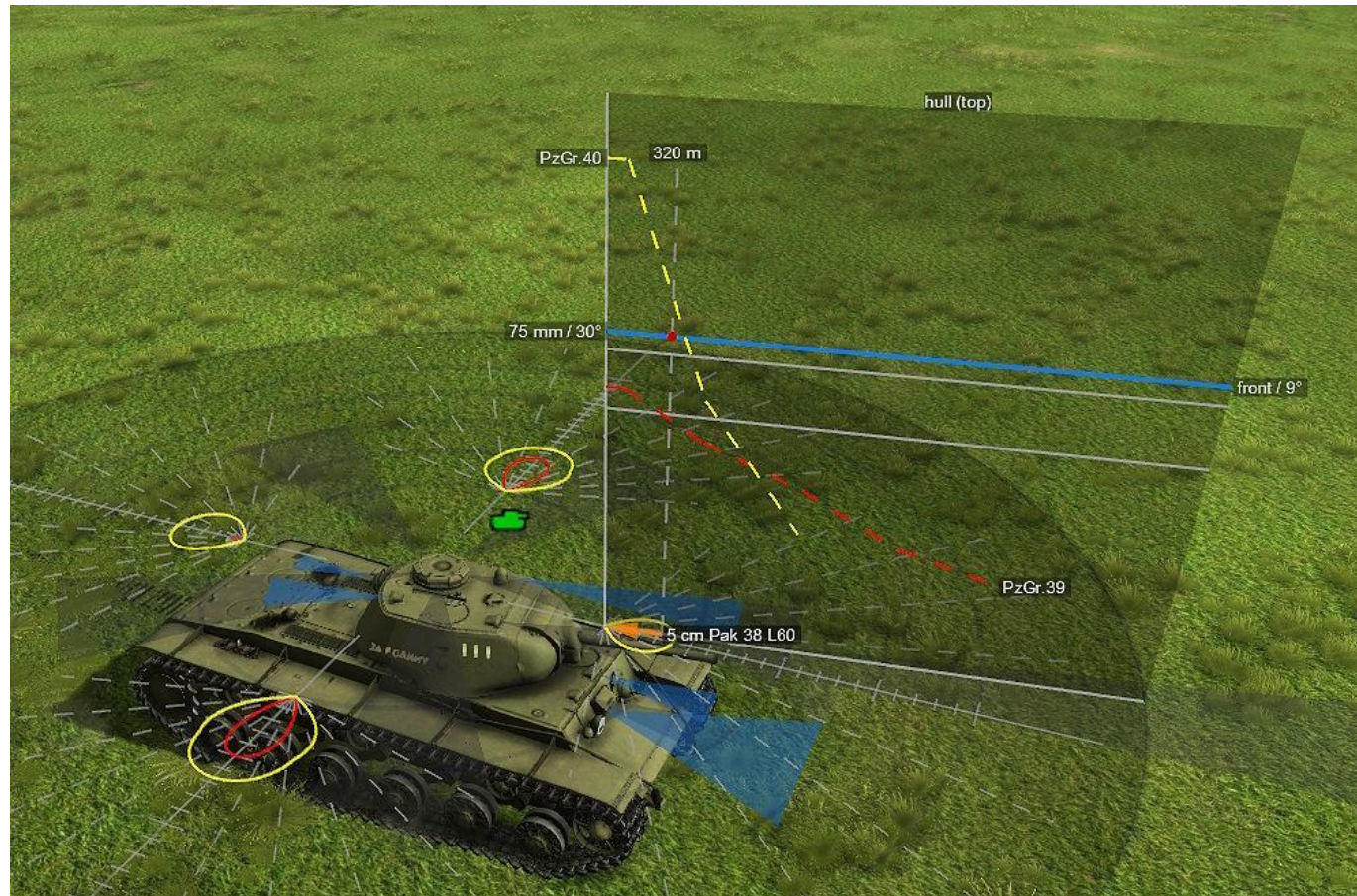

Real armor penetration diagram and chart examples.

Armor penetration of German artillery projectiles of Soviet tanks of the early war

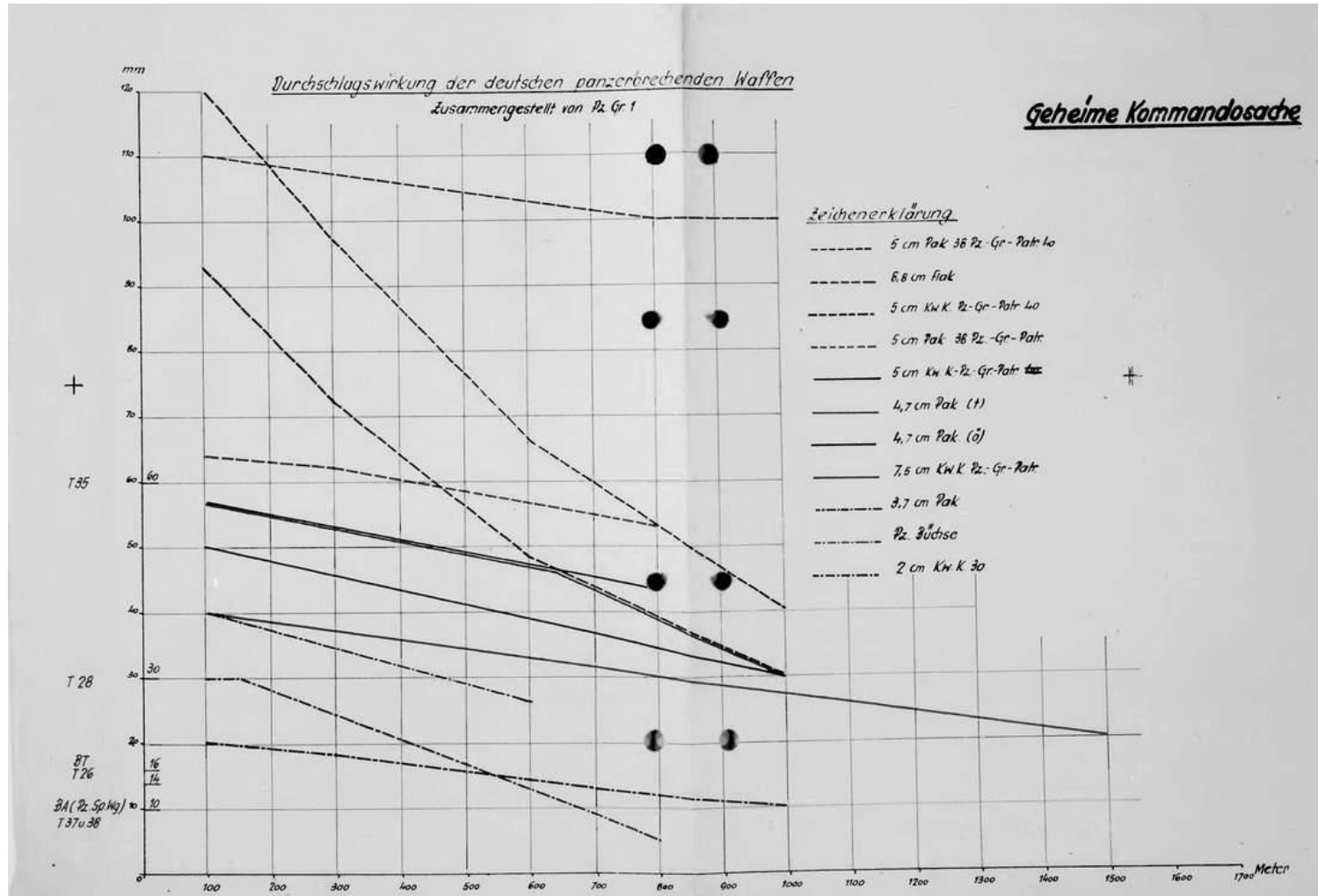

Bear in mind that the diagrams in the game are plotted for an impact angle of 30 degrees. And air temperature affects piercing performance of projectiles in battle. At low temperatures, the initial velocity of projectiles decreases and as a result, their piercing performance decreases.

3.6.1 Armor penetration calculation. The game simulates shells of various types: armor-piercing (solid and hollow), sub-caliber, cumulative of various types, high-explosive and high-explosive armor-piercing, as well as various special shells (smoke, incendiary, etc.).

When a projectile interacts with an obstacle, the armor penetration calculation is performed, depending on the kinetic energy available to the projectile, as well as its structural layout. If the projectile contains a fuse, the calculation of the need for its arming and action is also made. After contact with an obstacle, the projectile state is calculated: remained intact, ricocheted, broke or dispersed, stuck. If the projectile has lost kinetic energy and the fuse has not armed, it is excluded from further processing. If the projectile broke or dispersed, then its fuse would fail (if there is one). Projectiles with significant kinetic energy can hit several targets if it does not break when piercing the armor. Typically, breaking (and dispersion) occurs when a high-velocity projectile (with high kinetic energy) hits in adverse conditions: in thick armor, at an angle, or in inhomogeneities on the armor.

After piercing the armor or on impact with high kinetic energy without penetration, a fragmentation field is formed on the back of the armor, consisting of its fragments, which damages internal components and the vehicle crew. The total mass of fragments depends on the energy of the projectile, the thickness and characteristics of the armor. If the projectile has pierced the armor and broke or exploded, then its parts also participate in the formation of the fragmentation field.

Projectile fuses can be conditionally divided into two types: instant (in fragmentation and cumulative projectiles) and delay (shrapnel, fougasse, hollow). Provided that the projectile has a delay fuse, it becomes armed when breaching an obstacle, and then, after a time, the projectile is detonated (or after removal of load for projectiles with variable delay), this allows it to penetrate into the ground, or inside vehicles or a structure. However, the projectile may not explode if it breaks between fuse arming and acting. Also, projectiles can explode outside of the vehicle. For example, if a projectile pierced a thinly armored or unarmored vehicle all the way through.

3.6.2 Damage model. When projectiles or fragments hit the target, as well as when exposed to a shock wave, the calculation of possible damage is carried out: internal components, external parts, along with crew.

The magnitude of the damage depends on the kinetic energy for the projectile and fragments, and on the pressure at the front of the shock wave for high-explosive shells. The damage caused by the impact of the projectile on the vehicle frame is also calculated. In this case, damage usually is inflicted to fragile components of the vehicle: battery and radio station, as well as to external structural elements, such as the chassis. Incendiary means can cause engine failure or fire.

If fragments or projectile hit an ammo rack, fuel or oil tank, engine or transmission, a fire may occur (intense or slow burning). The probability of a fire depends on the energy of the fragments, the presence of fuel in the tanks (tanks filled by 10-12% have the greatest fire hazard). The probability of a fire also increases with a fuel spill, for example, if fuel tanks were damaged during previous hits in the vehicle or the ammo rack was damaged. If a vehicle is equipped with an automatic fire extinguishing system, then the fire may stop.

If fuel tanks or ammo racks are hit (and also after prolonged burning), detonation of ammo or tanks may occur. The probability of detonation depends on the presence and type of ammunition. Cumulative and high-explosive ammo are especially dangerous in terms of detonation. Penetration of fuel tanks results in fuel leakage and subsequent engine failure.

If the gun and turret rotation mechanisms are damaged, they may jam or the recuperator may fail, in which case the gun will not return from the recoil after a shot, and the vehicle will not be able to fire from this gun.

If the tank crew is hit, the remaining crew members may panic and abandon the tank or abandon the position and disengage.

4 AFTER BATTLE STATISTICS

In this phase (Fig. 4.1) the condition of all units, allied and enemy (Fig.4.2) after the battle (Table 4.1) and vehicle hits (Table 4.2-4.3) can be viewed.

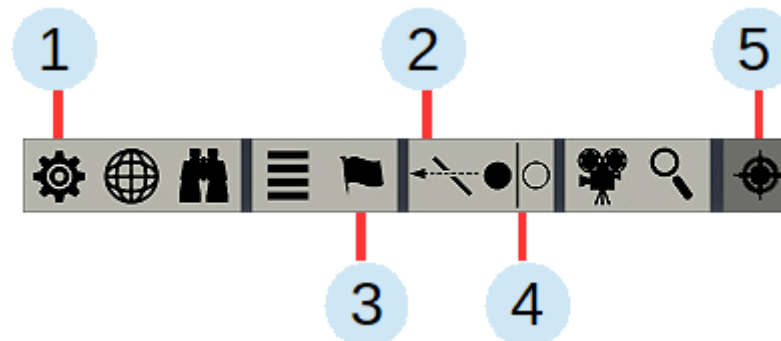

Fig. 4.1 - Statistics control interface

1) Back to overall statistics parameters [Esc]	2) Toggle hit vectors display mode: all, penetrations, only damage
3) Enable area ownership indication	4) Toggle the impact filter: everything, fragments and shells, impact and blast wave
5) Jump to unit which destroyed the selected unit	



Fig. 4.2 - Quick select panel in statistics

1) Enemy platoon - at the end of list (on gray background)	2) Selected unit from enemy platoon
--	-------------------------------------

Table 4.1 - Additional information in statistics phase









Symbol	Designation	Comment
	Hits received	
	Fire	Vehicle burned down beyond repair
	Vehicle lost	
	Vehicle needs repair	Man-hours required for vehicle damage repair
	Enemy vehicles destroyed (captured) by this unit, units	
	Enemy personnel destroyed (captured) by this unit, men	
	Main weapon fire accuracy %	Shots fired to hits to enemy ratio
	Secondary weapon fire accuracy %	

Table 4.2 - Ammunition color coding

cyan	shrapnel or canister	yellow	subcaliber
blue	high-explosive or high-explosive plastic	green	shaped charge
white	smoke or incendiary	red	cavity armor-piercing or solid armor-piercing

Table 4.3 - Damage types

light	illumination devices	*, ammo	fire, ammo storage
sight	sighting and observation devices	gear, chassis	gearbox, chassis
dr	driver-mechanic	radio, bat	radio, accumulator battery
gn, mg	gun-layer, machine-gunner	fuel	fuel tanks
ld, cm	loader and commander	gun, turret, recp	gun and turret mechanisms, recuperator
tr	troopers	trk, wheel	caterpillar track, wheel
fcs	fire control system	stab	stabilizer
eng, transm	engine, transmission	weap1, weap2	main and secondary weapons

Capital letters indicate fully disabled components and crew members.

4.1 Using captured weapons and vehicles

Captured weapons and vehicles are centrally collected after battle, in the controlled area. The collected weapons are distributed to the units participating in battle (shown in the "CASUALTIES AND CAPTURES" table). Captures are distributed based on the distance and applicability in a particular unit: small arms to infantry units, equipment to tank and artillery units.

Captures are used in two cases:

- 1) If a unit has not enough ammo (less than 25%) for standard weapons, in this case it will be rearmed to capture small arms.
- 2) If vehicles or heavy weapons are in IV category (non-repairable), in this case captured equipment will be used.

To use captures, their quantity, of the appropriate type, must be greater than or equal to 1 (in the "CASUALTIES AND CAPTURES" table). Personnel experience is reduced when rearming to capture. Units armed with captures are marked with '?'.

Captured weapons can be selected in the quick battle editor as well, by setting a value of less than 25% in the ammo quantity section.

5 MISCELLANEOUS

System requirements:

CPU	AMD FX 8120 or Intel i5 3 GHz
RAM	4 GB
Video card	ATI Radeon 7800 or nVidia GeForce 680 2 GB
Operating system	Windows 7 SP1, 8.1 or 10

You need to install additional software from the "docs\support\redists" folder in the main game folder to run it properly. It is recommended to install the latest drivers for your video card.

Latest updates can be downloaded here:

Microsoft DirectX – <https://www.microsoft.com/en-us/download/details.aspx?id=8109>

nVidia drivers – <http://www.nvidia.com/page/home.html>

ATI/AMD drivers - <http://www.amd.com/en-us>

When installing the game the required software will be installed automatically.

It is strongly recommended to disable forced anti-aliasing (smoothing) settings in the drivers!

5.1 Game updating and add-on installation

Add-ons (DLC) and game mods are installed using special utility (Fig.5.1), which can be accessed by clicking on the game version in the main menu (in the top right corner of the screen).

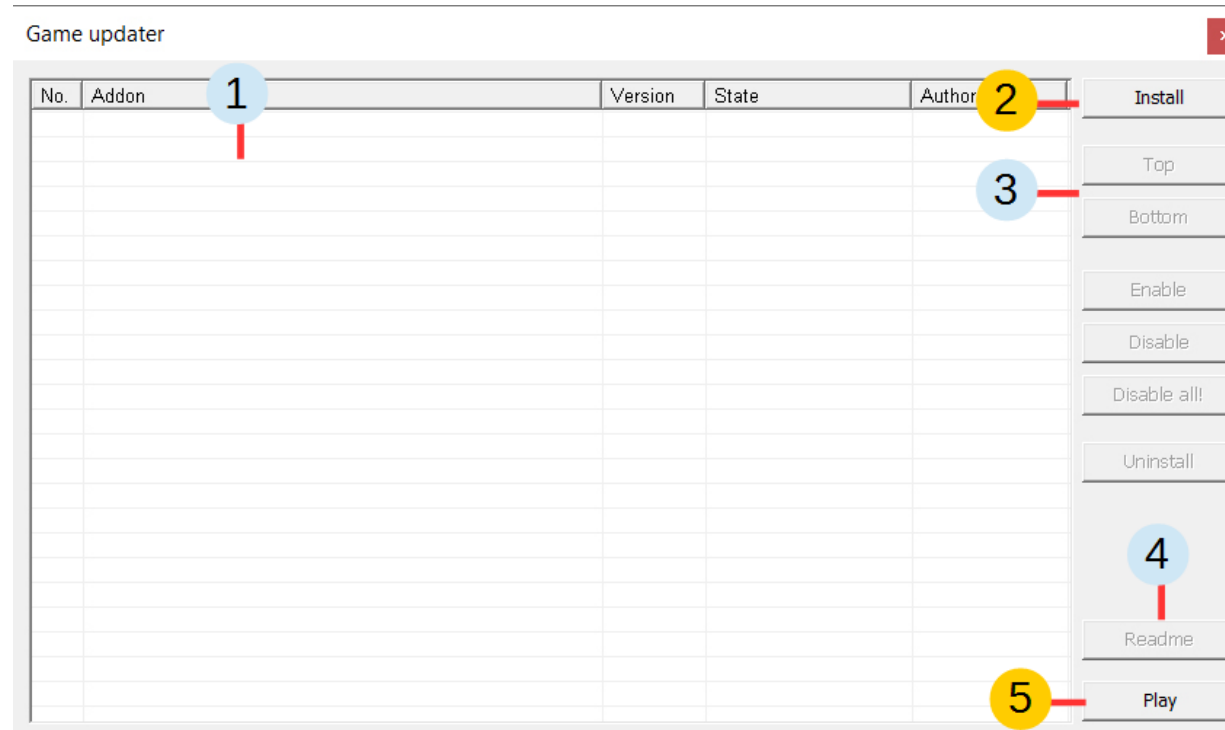

Fig. 5.1 - Add-on and mods installation utility interface

1) List of installed add-ons	2) Press to install new add-on
3) Add-ons rearrangement	4) Information about selected add-on
5) Play the game!	

Add-on located higher in the list Fig.5.1/1 has a higher priority. If add-ons don't modify the same game resources, their order is not important. Add-ons can be installed automatically, if they are placed (downloaded) in the new_updates folder in the root folder of the game, or by clicking on a file with .gt3ext extension in Explorer.

5.2 Armor penetration diagrams in the encyclopedia

Armor penetration diagrams can be viewed in the ENCYCLOPEDIA (Fig. 5.2). Diagram depicts the relationship of armor penetration of the shell to the distance, and the shell ability to penetrate the selected vehicle part from a certain angle (to switch the vehicle part for which the diagram is shown - click on the diagram margin). Diagram is plotted with reference to projectile impact at an angle of 30 degrees.

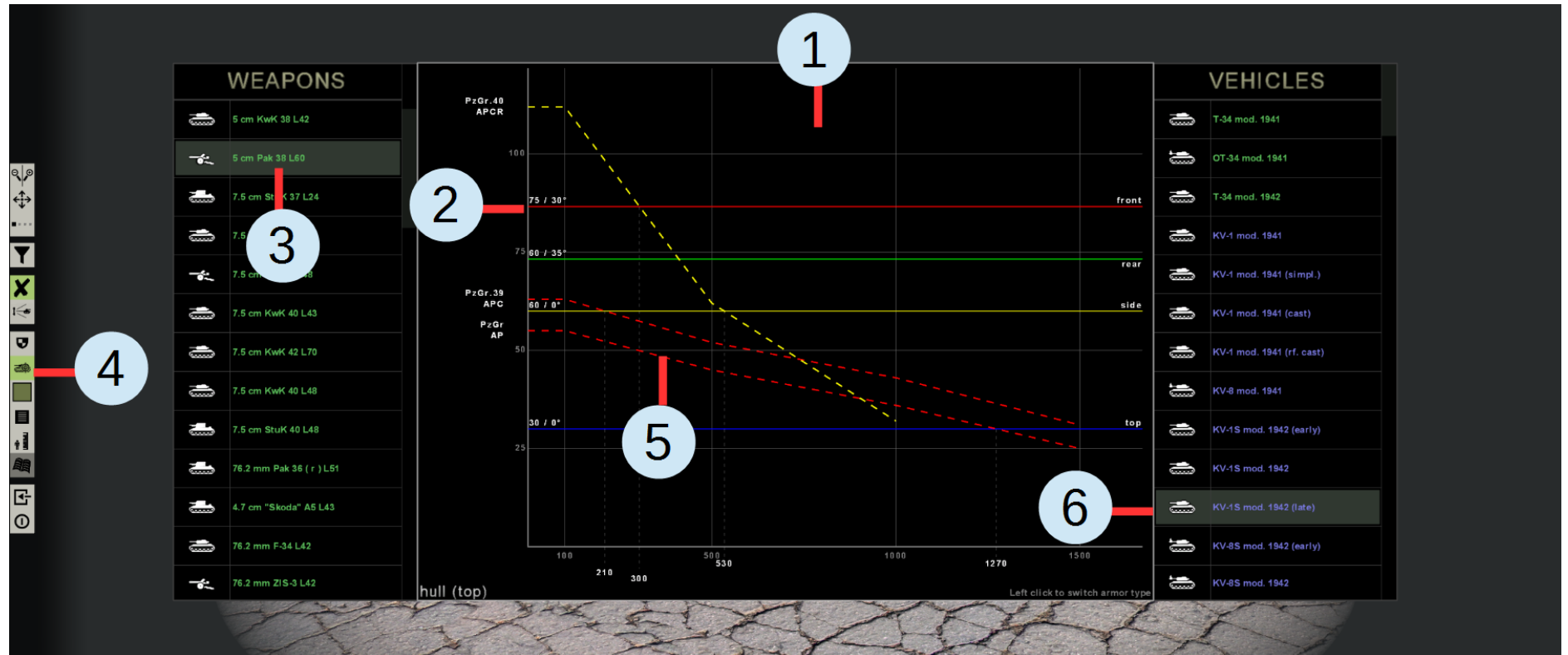

Fig. 5.2 - Armor penetration diagrams

1) Diagram image	2) Horizontals - armor thickness and typical armor angles
3) Vehicle for which diagrams are drawn	4) Button enabling the diagrams view
5) Broken lines - armor penetration	6) Weapon for which diagram is drawn (Table 5.1)

Table 5.1 - Chart colors for various shell types



Red	Cavity armor-piercing (APHE) or solid armor-piercing (AP)	Cyan	Shrapnel (SH) or canister shells (CAN)
Yellow	Subcaliber shells of all types (APCR, APDS, APFSDS)	Green	Shaped charge (HEAT) and high-explosive plastic shells (HESH)
Dark-blue	Fragmentation (FRAG) or high-explosive shells (HE, HE-T, HEP-T)	White	Smoke (SMK) or incendiary (FLAM) shells

Diagrams should be used to determine a pessimistic estimation of the distance at which a gun penetrates (not destroys!) an enemy armored vehicle, or to determine the distance at which the fire of the selected enemy weapon will be ineffective with a high probability.

5.3 Creating modifications

Game has the ability to create user modifications: single missions, sounds and textures of soldiers and vehicles. To create a modification you need to go to the “Modifications” section by pressing the appropriate button (in the shape of a wrench) in your profile. After that, choose the modification type from valid options (Table 5.2) and set a name for it.

Table 5.2 - Modifications

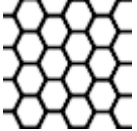
Type	Description
 Missions	Set of single-player missions. Set will include all missions with .mispack extension from the mod folder. After installation, mission will appear in the appropriate section of game
 Sounds	Sounds of engines, explosions, shots, collisions, fire burning, and others. Modified sounds should be placed in the modification folder in WAV format 44 kHz, 16 bit, Mono with .wav* extension (_sounds_list.txt)
 Textures	Textures of soldiers and vehicles. Modified textures should be placed in the modification folder in DDS format (DXT1 or DXT5) with .dds* extension (_textures_list.txt)

*Sounds and textures replace game files, so there is no need to duplicate every game file - only the ones changed.

After creating a modification it is necessary to set the folder ("Select folder") where the files to replace will be stored. If needed, you can get a list of game files (by clicking the "Source files" button) with the names and formats (for sounds and textures) and the game files themselves for modifying (for textures) - they will be placed in the modification folder.

After making all changes and creating the modification files, press the "Build" button. Modification archive will be created in the mod folder, which can be used in the game. To test the modification press the "Install" button - the game updater utility (see Section 5.1) will be launched, which will install the modification.

Appendix B. Short names of troops on the operational map

Table B.1 - Soviet troops

A	Army	AR	Artillery Regiment
ABD	Airborne Division	ABRR	Airborne Rifle Regiment
Armcar Bn	Armored Car Battalion	AT Destr Reg	Anti-Tank Destroyer (Artillery) Regiment
atk A	Attack Army	brt TR, BTR	Breakthrough Tank Regiment
destr AT Arty Bde	Anti-Tank Destroyer Artillery Brigade	Destr Bde	Destroyer Brigade (ie AT guns and AT rifles Brigade)
det, sep	Detached, Separate	ft Tank Bn	Flamethrower Tank Battalion
gds	Guards	hvy SPGR	Heavy Self-propelled Artillery Regiment
LABde	Light Artillery Brigade	LAR	Light Artillery Regiment
MC	Mechanized Corps	Mnt RBde	Mountain-rifle Brigade
MR Bde	Motor-rifle Brigade		
RBde	Rifle Brigade	RC	Rifle Corps
RD	Rifle Division	RGK	HQ Reserve
RR	Rifle Regiment		
TBde	Tank Brigade	TC	Tank Corps
TR	Tank Regiment		

Table B.2 - German troops

A	Army	AC, TAC	Army Corps, Tank Army Corps
AFD	Airfield Division	AFR	Airfield Regiment
AR	Artillery Regiment	AT Bn	Anti-tank battalion
B.gr., BG	Battlegroup		
gr.	Group (ie Battalion Battlegroup)	GrR	Grenadier Regiment (ie Motor-infantry Regiment)
ID	Infantry Division	IR	Infantry Regiment
LID	Light Infantry Division	MD	Mountain Division
MID	Motor-infantry Division	MIR	Motor-infantry Regiment
motor cyc. Bn	Motorcycle Battalion		
OKH	HQ Reserve	reinf	Reinforced
Tank Bn	Tank battalion	TD	Tank Division
TD Bn	Tank destroyer battalion (ie Anti-tank battalion)	TR	Tank Regiment

Table B.3 - US troops

ArmD	Armored Division	AFA Bn	Armored Field Artillery Battalion
ArmIR	Armored Infantry Regiment	ArmR	Armored Regiment
AT Bn, TD Bn	Tank Destroyer Battalion	CC	Combat Command
FA	Field Artillery Battalion	FAR	Field Artillery Regiment
ID	Infantry Division	IR	Infantry regiment, Combat Team
Rngr	Ranger Battalion	TF	Task Force

Table B.4 - British troops

1 Surrey	1st Battalion East Surrey Regiment	5 Buffs	5th Battalion Buffs (East Kents)
5 E.York	5th Battalion East Yorkshire Regiment	6 Kents	6th Battalion Royal West Kents
7 Gr.Howards	7th Battalion Green Howards Regiment	8 Argyll	8th Battalion Argyll and Sutherland Highlanders
DLI	Durham Light Infantry Regiment		
IBde	Infantry Brigade	ID	Infantry Division
NIH	North Irish Horse Tank Regiment		
RTR	Royal Tank Regiment	TR	Tank Regiment